

Kodak Professional

RP 30 LASER PRINTER OPERATOR'S GUIDE



Operator's Guide

KODAK PROFESSIONAL RP 30 Laser Printer

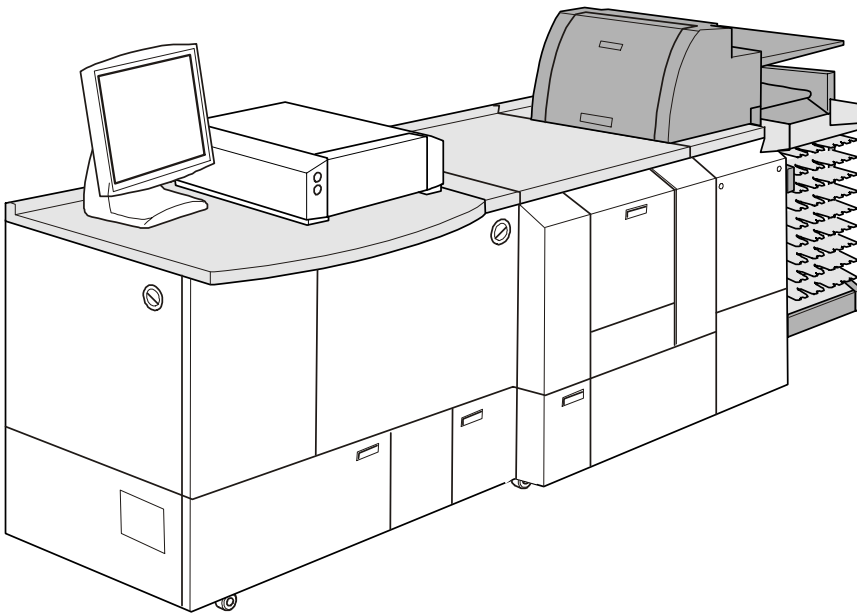

P/N 6B7444
December 2002

© Eastman Kodak Company, 2002

All rights reserved. Contents of this publication may not be reproduced in any form without permission from Eastman Kodak Company.

Table of Contents

Regulatory and Safety Information	iii
Regulatory Compliance	iv
Cautionary Symbols and Labels.....	iv
Laser Compliance and Safety	v
Safety Precautions	viii
Handling of Processing Chemicals.....	ix
Warranty Information	xi
Chapter 1 Introduction	1-1
Using the Documentation	1-3
Safety Precautions	1-4
Storage of Chemicals and Paper	1-4
Chapter 2 Overview	2-1
Components	2-3
Switching On the Equipment	2-10
End of Work	2-14
Operating Controls	2-18
Screen Structure.....	2-20
Menu Overview.....	2-28
Info.....	2-34
Help	2-40
Chapter 3 Chemicals	3-1
Preparation of Chemicals	3-3
Other Operations to be Performed Prior to Production Start	3-8
Chapter 4 Settings	4-1
From the Order Receipt to the Finished Print	4-3
Preparation of the Print Configuration	4-5
Settings.....	4-11
Machine Settings	4-14
Print Configurations	4-40
Saving and Loading Settings and Configurations	4-64
Chapter 5 Tests	5-1
Introduction	5-3
Printer Tests	5-3
Testing the Paper Processor	5-10

Chapter 6 Production	6-1
Preparing the Equipment for Different Orders	6-3
Order Processing	6-9
Print Modes	6-11
Printing File Print.....	6-12
Network Orders	6-25
Finishing Print Orders	6-26
Chapter 7 Correcting System Conditions	7-1
System Errors	7-3
Error Handling	7-5
Removing Paper Jams.....	7-8
Chapter 8 Maintenance	8-1
Maintenance Schedule and Maintenance Intervals	8-3
Daily Maintenance	8-4
Weekly Maintenance.....	8-6
Monthly Maintenance	8-22
Maintenance When Required	8-37
Consumables	8-39

Regulatory and Safety Information

Contents

Regulatory Compliance	iv
EMC Compliance.....	iv
CE Compliance.....	iv
Cautionary Symbols and Labels.....	iv
Hot Surface Symbol.....	iv
Electrical Hazard Symbol	iv
Mechanical Hazard Symbol.....	v
Laser Compliance and Safety	v
Certification Labels	vi
Non-interlocked Panel Label	vi
Aperture Label	vi
Laser Source Label	vii
Locations of Laser Safety Labels	vii
Safety Precautions	viii
Legal Notice.....	viii
General Precautions.....	viii
When Operating the Equipment	viii
When Disposing of the Equipment	viii
Handling of Processing Chemicals	ix
Disposal of Chemicals and Containers	ix
Effluent Management	ix
Chemical Concentrates	ix
Chemical Filters.....	ix
Container Recycling and Disposal	ix
Assistance from Kodak.....	ix
Safety Precautions for the Handling of Chemicals.....	x
General Guidelines.....	x
Skin and Eye Protection	x
Storage and Disposal	x
Warranty Information	xi
Warranty Period.....	xi
Warranty Repair Coverage.....	xi
How to Obtain Service.....	xi
Limitations	xii

Regulatory Compliance

EMC Compliance

NOTE: This equipment has been tested and found to comply with the limits for a Class A digital device, pursuant to Part 15 of the FCC rules. These limits are designed to provide reasonable protection against harmful interference when the equipment is operated in a commercial environment. This equipment generates, uses, and can radiate radio frequency energy and, if not installed and used in accordance with the instruction manual, may cause harmful interference to radio communications. Operation of this equipment in a residential area is likely to cause harmful interference in which case the user will be required to correct the interference at his or her own expense.

CE Compliance

WARNING: *This is a Class A product. In a domestic environment this product may cause radio interference in which case the user may be required to take adequate measures.*

Cautionary Symbols and Labels

Hot Surface Symbol



CAUTION: Hot surface. Allow the surface to cool before you touch it.

Electrical Hazard Symbol



CAUTION: Risk of electrical shock. To avoid shock, do not remove the panel.

Mechanical Hazard Symbol



CAUTION: Moving parts. Avoid contact. Keep your hands, hair, loose clothing, and jewelry away from moving parts.

Laser Compliance and Safety

The KODAK PROFESSIONAL RP 30 Laser Printer is equipped with an Argon Ion Laser of Class 3B. To prevent damage caused by the laser beam, the laser is encapsulated. Because the laser is encapsulated the entire RP 30 Laser Printer is classified as a Class 1 Laser Device.

This product complies with 21 CFR Chapter I, Subchapter J.

This is a Class 1 laser product.

The laser beam cannot strike the operator when the machine is operated under normal conditions, even when the machine doors are open.

WARNING: *Never remove or open covers to the laser modules. A laser beam of class 3B may be accessible after the removal of covers.*

There are no user-serviceable parts in the laser module of the RP 30 Laser Printer.





CAUTION: Use of controls or adjustments, or performance of procedures other than those specified herein may result in hazardous radiation exposure.

Labels on the equipment identify the laser and the laser module.

Certification Labels

Kodak Professional RP 30 Laser Printer		
SERVICE CODE	3809	PRINTER SERIAL NUMBER
		DATE OF PRINTER MANUFACTURE
 EASTMAN KODAK COMPANY Rochester, NY 14650 Made in Germany		P/N 2J8898

A

Kodak Professional RP 30 Laser Printer		
SERVICE CODE	3809	PROCESSOR SERIAL NUMBER
		DATE OF PROCESSOR MANUFACTURE
AC 220/360 V, 230/400 V, 240/415 V 50/60 Hz 16 A 3W+N+PE AC 200/210/220/230/240 V 50/60 Hz 25 A 3W+PE AC 200/210/220/230/240 V 50/60 Hz 32 A 2W+PE or 1W+N+PE		
   		This device complies with Part 15 of the FCC rules. Operation is subject to the following two conditions: (1) This device may not cause harmful interference, and (2) this device must accept any interference received, including interference that may cause undesired operation. This class A digital apparatus complies with Canadian ICES-003. Cet appareil numérique de la classe A est conforme à la norme NMB-003 du Canada. This product complies with 21 CFR Chapter I, Subchapter J.
 EASTMAN KODAK COMPANY Rochester, NY 14650 Made in Germany		P/N 7E9008

B

Class 1 Laser Product
according to IEC 60825-1

C

Non-interlocked Panel Label

<p style="text-align: center;">DANGER LASER RADIATION WHEN OPEN AVOID DIRECT EXPOSURE TO BEAM</p> <hr style="width: 80%; margin: 5px auto;"/> <p style="text-align: center;">VORSICHT! LASER STRAHLUNG TRITT AUS. WENN DECKEL GEÖFFNET IST! NICHT DEM STRAHL AUSSETZEN!</p>	<p style="text-align: center;">PELIGRO RADIACION LASER CUANDO SE ABRA EVITE LA EXPOSICION DIRECTA DEL HAZ</p> <hr style="width: 80%; margin: 5px auto;"/> <p style="text-align: center;">DANGER RAYONNEMENT LASER A L'OUVERTURE EVITER TOUTE EXPOSITION DIRECTE AU RAYON</p>
---	--

D

Aperture Label



AVOID
EXPOSURE

LASER RADIATION IS EMITTED
FROM THIS APERTURE

E

Laser Source Label

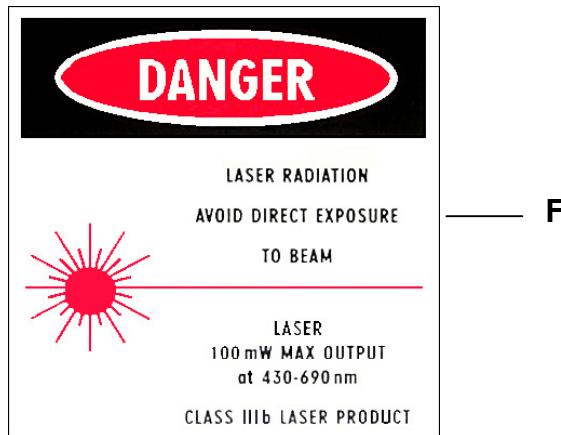

Locations of Laser Safety Labels

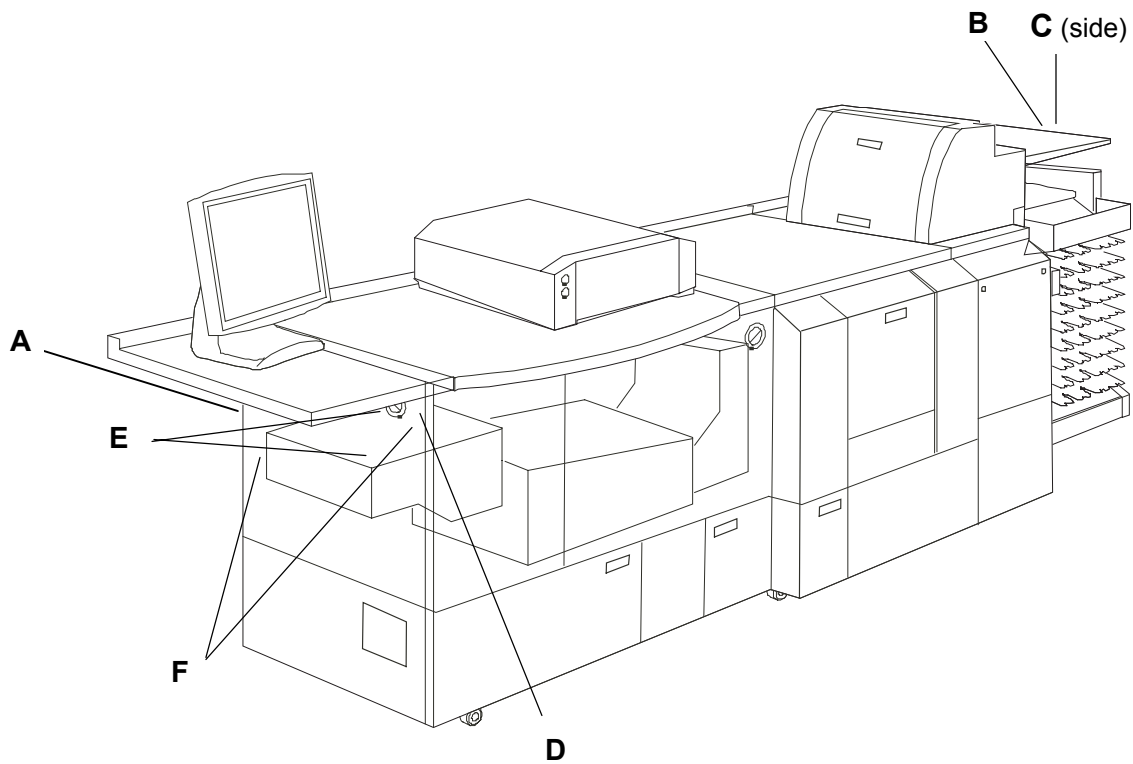

Safety Precautions

Legal Notice

The RP 30 Laser Printer is designed for operation in conformance with all local safety regulations.

Follow all safety regulations, warnings, and instructions on machine labels. Failure to observe these regulations may result in personal injury or damage to the equipment and working area.

The manufacturer and service provider will not assume any responsibility for accidents and damage resulting from incorrect operation.

General Precautions

- Never modify or rewire electrical circuits.
- Do not circumvent or disable the integrated safety devices.
- Do not modify preset values of safety components.
- Replace fuses only with the same type of fuse (amp value, switch-off characteristics).

When Operating the Equipment

WARNING: *Do not operate the equipment without the covers and panels. Persons who open or remove covers expose themselves to dangerous voltages and other risks of injury.*

- Do not cover or block the vent openings in the housing. This may lead to overheating of components.
- Do not allow objects or liquids to enter the equipment through the vent openings. This may cause fire or electrical shock.
- Do not allow the power cable to be squeezed or crimped. Install the power cable so that it will not cause someone to step on or trip over it.
- Avoid the excessive generation of dust. This may damage the components in the machine.

When Disposing of the Equipment

The RP30 contains a small amount of lead in circuit boards and mercury in the backlight of the LCD monitor. Disposal of these materials may be regulated due to environmental considerations. For disposal or recycling information, please contact your local authorities, or in the USA, visit the Electronics Industry Alliance website at www.eiae.org.

Handling of Processing Chemicals

Disposal of Chemicals and Containers

Effluent Management

IMPORTANT: *Regulations and requirements regarding the proper disposal of photographic processing effluents vary by region and by locality.*

If your facility will use on-site waste management procedures (for example, silver recovery units) for silver-bearing effluents, contact the municipal sanitary sewer authorities for the discharge requirements and permit application procedures, as applicable.

If you will manage silver-bearing effluents off-site, contact your local solid waste or hazardous waste authorities to obtain regulatory and permit guidance.

Because it is customary practice to discharge the non-silver bearing effluents to the sanitary sewer system, contact the sewer authorities about proper treatment at your local municipal treatment facility.

Chemical Concentrates

Certain concentrates may be considered hazardous waste and require special attention. If you must dispose of chemical concentrates as waste material, contact your local solid waste or hazardous waste authorities to obtain disposal information.

Chemical Filters

When you clean the chemical filters for the silver-bearing working solutions, collect the rinse water and direct it to a silver recovery unit for treatment or collect it for treatment at an off-site facility.

Container Recycling and Disposal

IMPORTANT: *Use cold water for rinsing all containers.*

In most regions, it should be possible to participate in your local community-recycling program. Check with the program authorities to determine if the packaging materials are eligible for local recycling. If they are eligible, disassemble the package and place the bottles and corrugated material in your recycling bin. Follow all material preparation instructions from the recycler. If local recycling is not an option, dispose of the empty bottles and the package with your normal solid waste.

Assistance from Kodak

For more information on waste management and recycling, visit www.kodak.com/go/kes.

Safety Precautions for the Handling of Chemicals

WARNING: *Be certain to follow these guidelines for the safe handling of chemicals in the equipment working area.*

General Guidelines

- Be sure that all persons operating the equipment have a complete set of instructions for the handling of dangerous substances.
- Be sure that all persons operating the equipment have training on the handling of dangerous substances at least once a year.
- Check for sufficient room ventilation in the working area. The air should be exchanged at least eight to ten times per hour.

Skin and Eye Protection

Photographic solutions contain substances that may irritate the skin, the mucous membranes, or the eyes. They may also cause allergic skin reactions. For all procedures where photographic processing solutions may splash (for example, preparing and filling in chemical solutions or cleaning processing racks), follow these guidelines:

- Avoid skin contact, especially with developer solutions.
- Wear protective gloves and change them every day, if possible. It may be necessary to also wear a rubber apron during some maintenance operations.
- Rinse all solutions that get on the skin with plenty of running water.
- Wear protective goggles. If splashes do get into the eyes, wash them immediately with plenty of water, lifting the eyelids away from the eyes. Then consult an eye doctor if irritation occurs.

Storage and Disposal

IMPORTANT: *Follow the guidelines for Disposal of Chemicals and Containers on Page ix.*

- Store chemicals and processing solutions in a safe place.
- Collect drained chemicals immediately and dispose of the solutions, observing the above provisions.
- Use cold water to rinse chemical residue from the KODAK EKTACOLOR Processing Cartridge 75 cartons before disposing of them.

Warranty Information

The following warranty information pertains to equipment that is installed in the United States only. For equipment installed in countries other than the United States, the terms and conditions of the new equipment warranty are provided by the Kodak company in the country in which the sale is finalized, or by a Kodak-appointed distributor in those countries where Kodak does not have direct sales representation.

Warranty Period

Kodak warrants new equipment to function properly for 90 days from the date of initial installation. This warranty covers the purchaser of the equipment as well as anyone else who owns it during the warranty period.

Warranty Repair Coverage

If this equipment does not function properly during the warranty period, a Service and Support Field Engineer from Kodak will repair the equipment without charge during Kodak's normal working hours (usually 8:00 a.m. to 5:00 p.m., Monday through Friday). Such repair service will include any adjustments and/or replacement of parts required to maintain your equipment in good working order. Supply items are billed as required.

How to Obtain Service

Before you call, please know your printer's K-Number.

For service and support:

- *In the United States:* call Eastman Kodak Company at 1-800-356-3253 (1-800-3KODAK3).
- *Outside the United States:* contact your local Kodak representative.

Limitations

Warranty service is limited to areas within Kodak's established marketing centers in the contiguous United States, the island of Oahu in Hawaii, and some areas of Alaska.

This warranty does not cover circumstances beyond Kodak's control; it does not cover service or parts for any attachments, accessories, or alterations not marketed by Kodak, or to correct problems resulting from their use.

Damage caused by failure to meet the electrical specification in this manual is not covered under the warranty to service agreement claim.

Kodak makes no other warranties, express, implied, or of merchantability, for this equipment.

Repair or replacement without charge is Kodak's only obligation under this warranty. Kodak will not be responsible for any consequential or incidental damages resulting from the sale, use, or improper functioning of this equipment, even if loss or damage is caused by the negligence or the fault of Kodak.

Such damages, for which Kodak is not responsible, include, but are not limited to, loss of revenue or profit, downtime costs, loss of use of the equipment, cost of any substitute equipment, and facilities or services of claims of your customers for such damages.

This limitation of liability does not apply to claims for injury to persons or damage to property caused by the sole negligence or fault of Kodak or by persons under its direction or control.

Chapter 1 Introduction

Contents

Using the Documentation	1-3
Structure	1-3
Text Styles	1-3
Notices.....	1-3
Safety Precautions	1-4
Storage of Chemicals and Paper	1-4

Using the Documentation

Structure

This Operator's Guide contains information about:

- Safety precautions
- Machine settings
- Print configurations
- Production
- Maintenance

Text Styles

In this guide, **bold print** indicates screen or button designations.

Examples:

“Touch **OK** to validate the displayed text and close the **Input screen**.”

“Touch **Network print** to process network orders.”

Italic print indicates cross-references.

Example:

“Also see the paragraphs under *Safety Precautions* on the following page.”

Notices

The following notices are used in this manual and on equipment labels:

- | | |
|-------------------|--|
| NOTE: | Contains parenthetical (information-only) material. This is the least urgent type of notice. |
| IMPORTANT: | <i>Contains information essential to correct operation of the equipment.</i> |
| CAUTION: | Indicates the potential for damage to or from the equipment. |
| WARNING: | <i>Indicates the potential for injury to persons operating the equipment.</i> |
| DANGER: | INDICATES THE POTENTIAL FOR SEVERE INJURY TO PERSONS OPERATING THE EQUIPMENT. |

Safety Precautions

See the *Regulatory and Safety Information* in the front of this guide for details about:

- Electrical precautions
- Operation of the equipment
- Disposal of the equipment
- Handling and storage of processing chemicals
- Laser safety

Follow all safety regulations, warnings, and instructions that are on equipment labels and in the guide.

Storage of Chemicals and Paper

Consumable	Storage Requirements
Chemicals	Store and prepare chemicals according to the manufacturer's specifications.
Photographic Paper	Store all color paper in a cool and dry location.
	Storage Temperature: 2 – 10°C (35 – 50°F)
	Relative Humidity (for open packages): 50 – 60%

IMPORTANT: *To avoid visible changes in the photographic paper, do not store the paper at temperatures above 30°C (86°F).*

NOTE: You can store photographic paper at 20°C (68°F) for several days.

Chapter 2 Overview

Contents

Components	2-3
Product Description	2-5
Image Editing.....	2-5
Functional Procedure	2-6
Printing Sequence	2-6
Main Computer	2-6
Printer	2-7
Paper Processor.....	2-7
Sorter.....	2-8
Densitometer	2-9
Switching On the Equipment	2-10
Automatic Switch-On.....	2-10
Manual Switch-On	2-11
System Start	2-12
Readiness for Operation	2-12
User Login	2-12
Start Screen.....	2-13
End of Work	2-14
Changing Users.....	2-14
Shutting Down	2-15
Automatic Shutdown.....	2-15
Manual Shutdown.....	2-16
Emergency Reset.....	2-17
Switching Off the Machine Partially (Sleep Mode).....	2-17
Operating Controls	2-18
Button and Lamp on the Main Computer	2-18
Touch-screen Monitor	2-19
Keyboard and Mouse	2-19
Screen Structure	2-20
Information Area	2-21
Touch-sensitive Buttons	2-23
Drop-down Menus	2-23
Pop-up Windows	2-24
Input Screen	2-26
Numeric Keypad	2-27
Menu Bar	2-27
Menu Overview	2-28
Main Menus	2-28
Print Mode Menu	2-29

Settings Menu (without Machine Settings)	2-30
Settings Menu (with Machine Settings)	2-31
Test Menu	2-32
End of Work Menu	2-33
Status Information / Help Menus.....	2-33
Additional Screens	2-34
Info.....	2-34
Info Printer.....	2-35
Info Paper Processor	2-36
Info Order	2-37
Version Info.....	2-38
Error List.....	2-39
Help	2-40

Components

The KODAK PROFESSIONAL RP 30 Laser Printer consists of three main components.

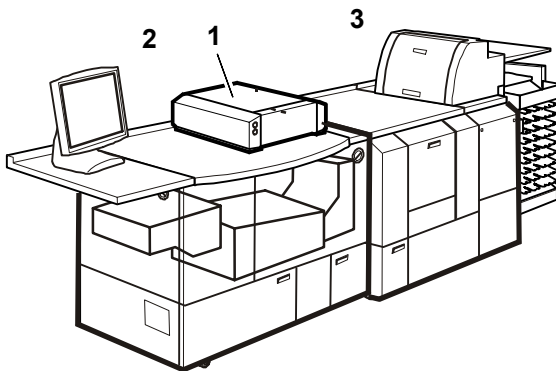

- 1 Main computer** – controls the complete program and generates print data. A touch-screen monitor is connected to the main computer.
- 2 Printer** – prepares and transports the paper size to be printed and uses a laser to print the digital image on paper.
- 3 Paper processor** – includes a connected sorter and a deposit tray for the prints.

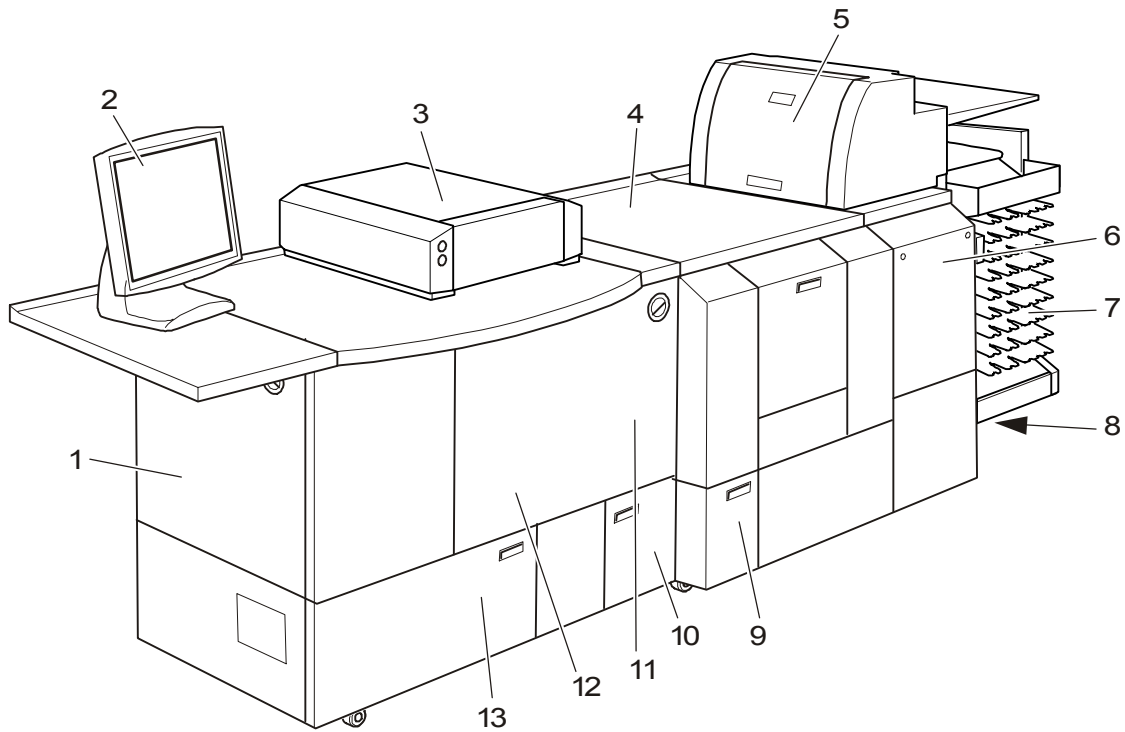

- | | |
|--|--|
| 1 Print engine with laser fiber and laser module | 8 Main switch, ground fault indicator (GFI) switch |
| 2 Touch-screen monitor | 9 Drain valves for the chemical overflow |
| 3 Main computer | 10 Right-hand paper magazine |
| 4 Wet section with racks, crossovers, and chemical filters | 11 Lane distributor |
| 5 Paper outlet with integrated densitometer | 12 Transport unit |
| 6 Dryer | 13 Left-hand paper magazine |
| 7 Order sorter | |

Product Description

The RP 30 Laser Printer provides convenient and quick printing of digital images.

The image files are transferred to the RP 30 Laser Printer from either:

- Network (workstation), or
- Data carriers
 - diskette
 - ZIP disk
 - CD-ROM or Smart Media card (by way of PCMCIA adapter)

NOTE: It is the customer's responsibility to provide for a network and/or a workstation and to provide for its connection.

Image Editing

The RP 30 Laser Printer offers a variety of image editing options:

- Color and density corrections
- Cropping
- Image enhancement
 - area and detail contrast
 - sharpness
 - saturation
- Special features
 - colored text
 - borders

These modifications are calculated on the image processing board. The image in the display refreshes immediately.

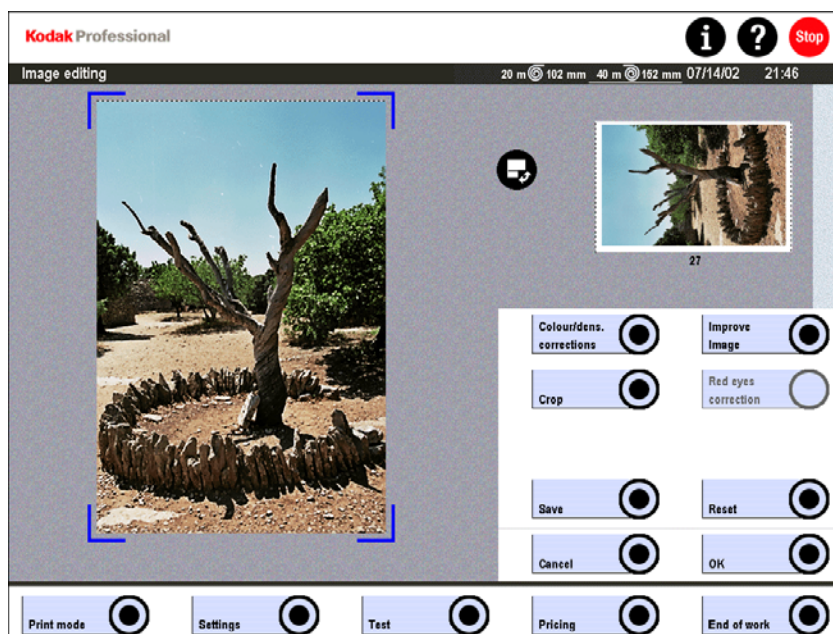

Functional Procedure

The RP 30 Laser Printer performs the following functions to process print orders.

- Loads the image information
- Cuts the paper
- Transports the paper
- Edits the images, if necessary
- Exposes the images
- Distributes the paper to the appropriate lane to the processor
- Processes the images
- Deposits the prints in the sorter

These functions are described in the following *Printing Sequence* section.

Printing Sequence

Main Computer

The main computer—by way of the integrated image processing board—processes image data, corrections, and the operator-entered image manipulations into a printable image, and sends the image to the printer.

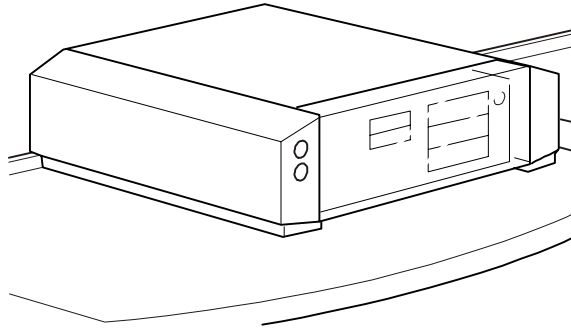

Printer

The printer transports the cut paper (1) to the print engine (2), exposes the paper to the laser beam, and advances it through the transport unit (3) up to the lane distributor (4). The back print (5) is applied in the lane distributor.

The lane distributor transports the print to the paper processor.

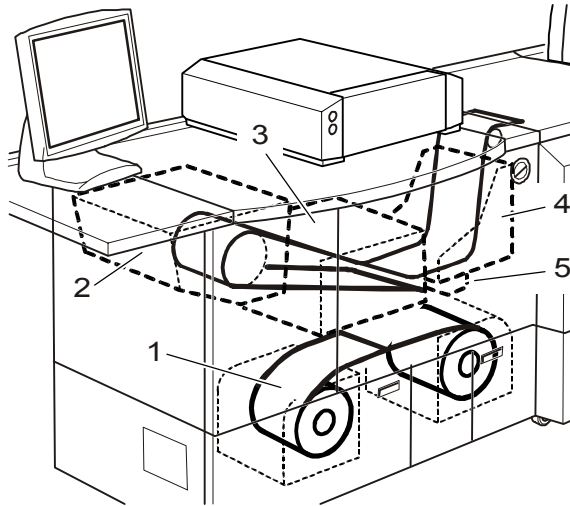

Paper Processor

The exposed paper advances through the processing solutions (1), which include the developer, bleach-fix, and stabilizer. The paper then advances through the dryer (2).

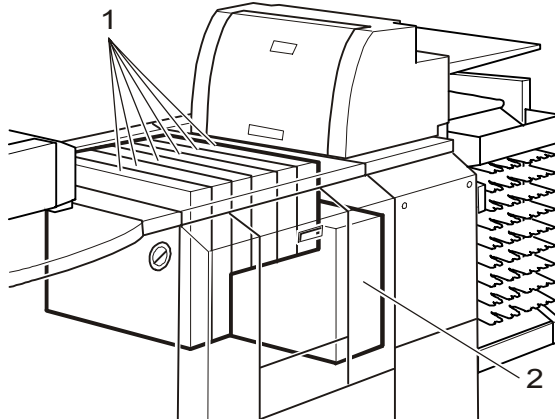

Sorter

After drying, the prints exit from the print chute (1) into the sorter (2), where they are sorted by orders and stacked in trays.

- If a print order exceeds the capacity of one tray (a maximum 43 prints), the sorter automatically switches to the next tray without terminating the print order.
- Splices in the paper rolls are cut separately and the respective pieces of paper are deposited in the print order stack.
- Large prints are deposited on the large print deposit tray (3).

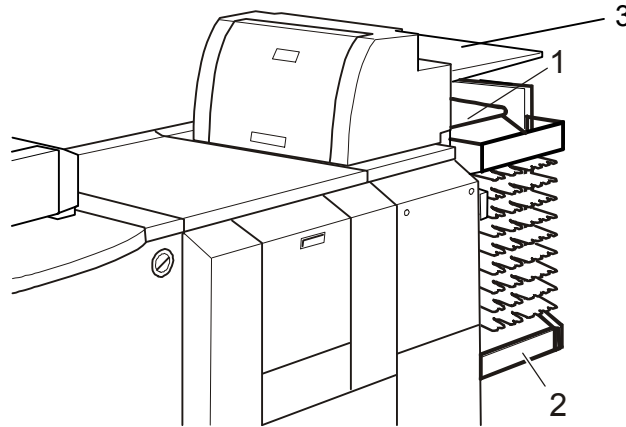

Densitometer

The built-in densitometer (1) above the dryer automatically measures the test print.

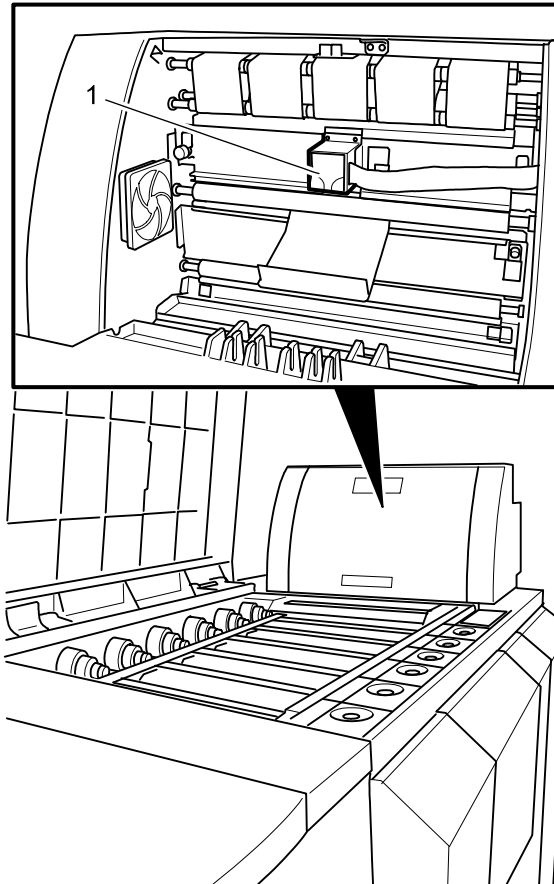

Switching On the Equipment

IMPORTANT: *Before switching on the equipment, insert the paper magazines, which are loaded with the appropriate size paper.*

The two methods of starting the RP 30 Laser Printer are:

- Automatically, by way of the integrated timer – the preferred procedure
- Manually, by pressing the ON button – the alternate procedure

The conditions for switching on the equipment are:

- The equipment was not previously switched off by way of the main circuit breaker.
- The supply voltages have not been interrupted, such as by fuses or circuit breakers or by a power failure.

Automatic Switch-On

To prepare the equipment to start automatically by way of the timer, set the timer to workdays / starting times and off days according to the instructions provided in *Startup: Defining the Start Time / the Standard User (Timer)*, in Chapter 4.

Manual Switch-On

1. Switch on the main circuit breaker (1).
2. Press the **ON** button (2), if necessary.

The ground fault interrupter (GFI) switch below the main circuit breaker always remains on.

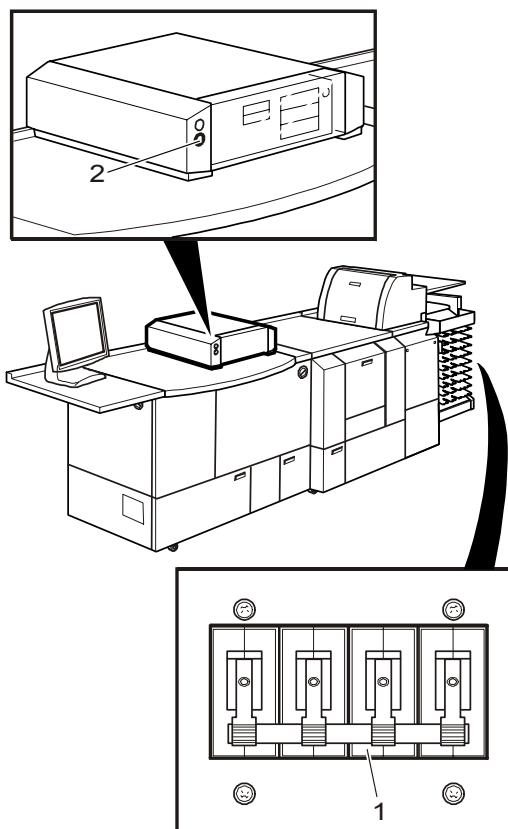

System Start

After automatic or manual switch-on, the equipment heats the solutions and the dryer to nominal temperatures. During this phase, the monitor displays:

- The progress of the startup / heating up in percent
- The remaining time until the machine is ready to operate
- Any error messages
- The **Stop** button to shut down the equipment correctly any time during the start-up process

The equipment is ready for operation after the solutions and the dryer have reached nominal temperatures.

Readiness for Operation

User Login

After the equipment has been switched on and heated up, the **Login** screen appears, where you enter your user name and password (four numbers). The user name is preset if you have been defined as the first user who must enter a password.

After you enter the user name (if required) and password, the **Start** screen appears. The **Start** screen appears immediately after warm-up if the first user is logged in automatically (the system does not check for a password). The **Start** screen also appears after a new user has logged in.

Start Screen

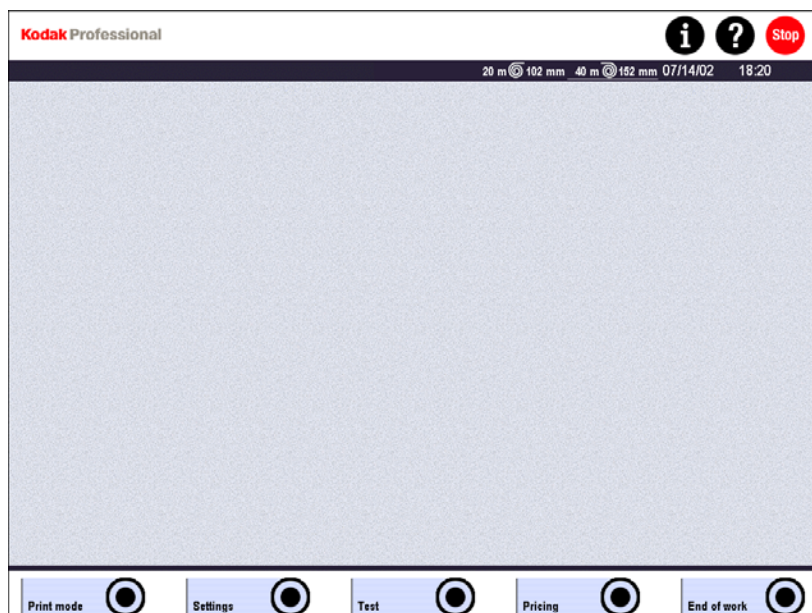

After you log in, the menu bar with the five main menus appears.

- **Print mode** offers all functions for image editing and printing (see *Production*, Chapter 6).
- **Settings** lets you create the print configurations and enter machine-specific parameters (see *Settings*, Chapter 4).
- **Tests** lets you test the equipment prior to the production start and during production (see *Tests*, Chapter 5).
- **End of work** lets you shut down the machine completely or partially (Sleep mode). A different user can also log in from this menu.
- **Pricing** is not available.

In the **Start** screen and in all screens that follow, only the functions that correspond to the user profile are displayed. Functions that are not available appear in gray.

If a function is not available, either:

- The logged-in user does not have permission to use this function.
- The software is not installed.

For more information, see *User Administrator: Defining Users and User Rights* in Chapter 4.

End of Work

Changing Users

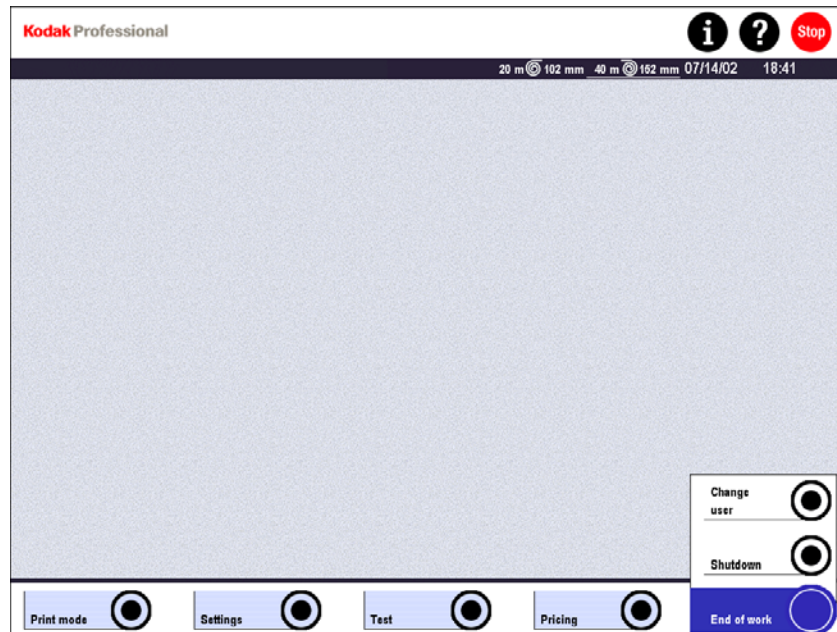

To change users, you must first log out.

1. Select **End of work** in the menu bar.
2. Touch **Change user**.
3. Touch **Logout**.

Work can continue only if a user follows these steps to log in again.

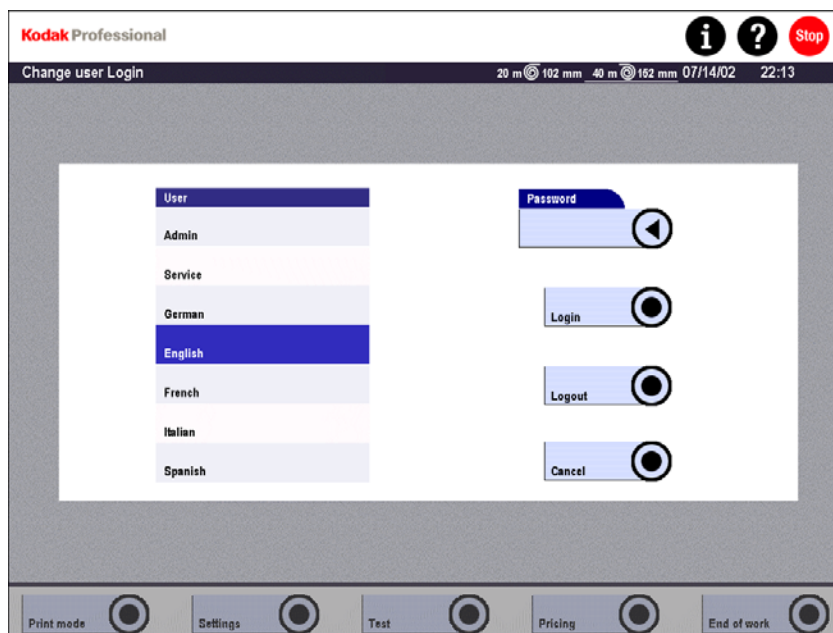

1. Select the name of the next user.
2. Enter the password (four numbers).
3. Touch **Login**.

If a different language is allocated to the new user in the machine setup, all text is displayed in this language.

Shutting Down

The two methods of shutting down the RP 30 Laser Printer are:

- Automatically, by way of the integrated timer – the preferred procedure
- Manually, by selecting **End of work** on the menu bar – the alternate procedure

Automatic Shutdown

The equipment switches off automatically if you enter no input within a preset time period after system start.

To define the preset time period, see *Machine Settings / Startup* in Chapter 4.

Manual Shutdown

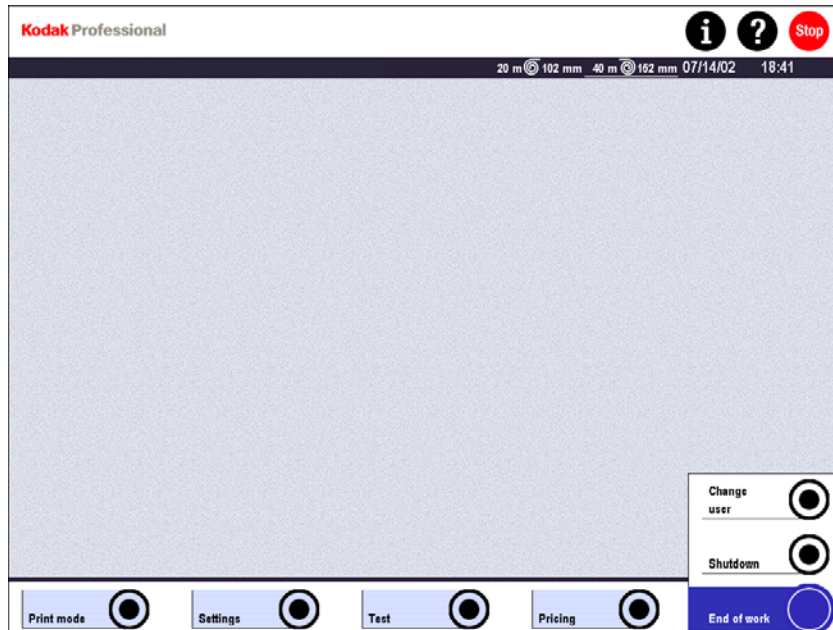

1. Select **End of work** in the menu bar.
2. Touch **Shutdown**.



3. Change the start information in the display, if necessary:
 - **Change Timer**
Change the date / time for the next start in the opening screen.
 - **Next Login**
Select the user for the next switch-on.

NOTE: Changes to the start time and user are only valid for the next start.
Permanent changes are only possible by way of the equipment settings.

4. Perform the daily maintenance procedures (see *Daily Maintenance* in Chapter 8).
5. If unprocessed orders exist, answer the query as to whether they should be saved. Orders that are not saved are lost.

The equipment is now shut down and switched off.

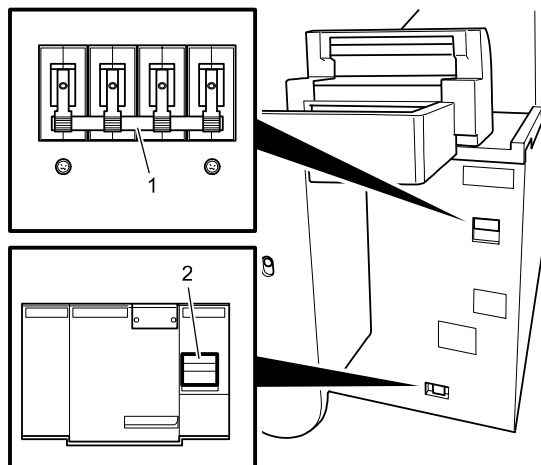

Emergency Reset

CAUTION: The main circuit breaker is for emergency reset only. If you switch off the printer with the main circuit breaker, the laser-cooling fan turns off and the service life of the laser is reduced if you do not immediately restore power.

If the computer is not responding and the printer cannot be switched off with either the automatic or the manual method, you can use the main circuit breaker to switch off the printer.

1. Switch off the main circuit breaker.
2. Wait 10 seconds.
3. Switch on the main circuit breaker.

Switching Off the Machine Partially (Sleep Mode)

It is possible to switch off parts of the general system so that only the main computer is running. This "Sleep" mode allows for statistical checks locally or by remote control, before the equipment is switched off completely. While in Sleep mode:

- The printer and paper processor are OFF.
- The main computer is ON.

You can activate the Sleep mode for the desired weekdays and enter the switch-off time of the main computer. Once the Sleep mode has been activated, the switch-off time of the main computer is indicated on the monitor.

For more information, see *Machine Settings* in Chapter 4.

Operating Controls

Button and Lamp on the Main Computer

There is one button and one lamp on the main computer:

- **ON** button (1)
If the system is shut down by **End of work – Shutdown**, it remains in the timer mode until the next automatic startup. If you must switch on the system before the next automatic startup time, press the **ON** button. The system will then start up. Additionally, you can press the **ON** button to initiate a reset.
- The timer lamp (2) lights if the system is in the timer mode after **Shutdown**.

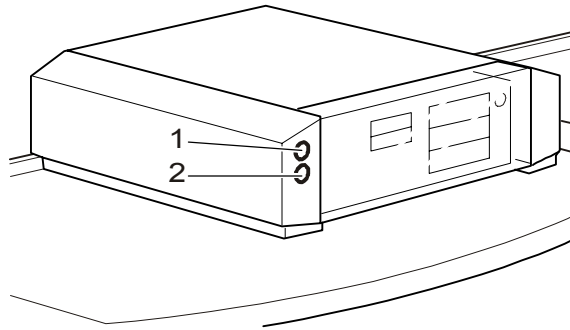

For more information, see:

- *Automatic Switch-On on Page 2-10.*
- *Reset with the ON Button or Stop Button on the Screen in Chapter 7.*

Touch-screen Monitor

The operation of the equipment is menu-driven by a touch-screen monitor. You activate the functions by touching the touch-sensitive buttons on the screen.

Specifications:

- 15-inch LCD screen
- SVGA resolution 1024 x 768 pixels
- Screen-refresh frequency > 75 Hz

For more information, see *Screen Structure* on *Page 2-20*, *Touch-sensitive Buttons* on *Page 2-23*, and *Menu Overview* on *Page 2-27*.

Keyboard and Mouse

You can connect a standard keyboard and mouse on the left panel and use them as an alternative to the touch-screen monitor to select and activate the buttons in the menus.

Screen Structure

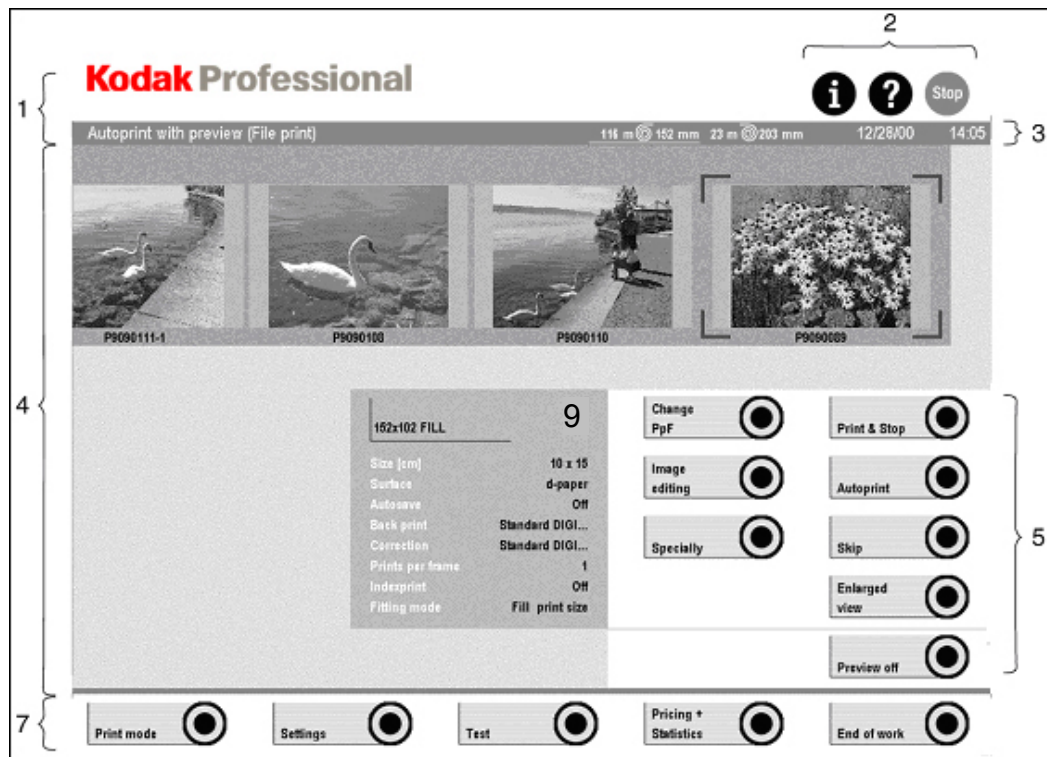

NOTE: This operator's guide refers to the touch-sensitive fields of the touch-screen monitor as "buttons."

The screen is divided into different areas:

- 1 Information area
- 2 Fixed buttons (i, ?, and
- 3 Stop)
- 4 Status line
- 5 Active screen
- 6 Buttons
 - Pop-up window, if available (not shown in the above example)
- 7 Menu bar with five main menus

The areas 1, 2, 3, and 7 are always displayed. However, the menu bar (7) cannot always be used. When certain errors occur, it is disabled until the errors are removed.

Information Area

The Information area includes the fixed buttons (i, ?, and **Stop**) and the status line.

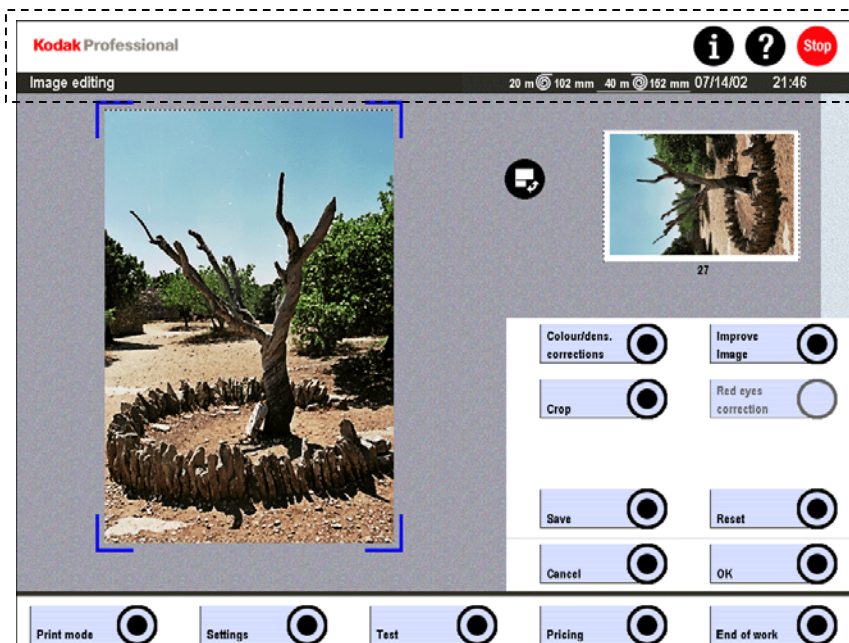

Because the fixed buttons are always accessible, you can open the Info and Help screens at any time. For more information, see *Info* on Page 2-34 and *Help* on Page 2-40.

The fixed buttons are described below.

- i** Status information
- ?** Context-related help function for all screens and error messages
- Stop** If the system does not respond to operator entries, you can use this button to initiate a software reset. The entire RP 30 Laser Printer is stopped (orders are interrupted and all major assemblies are reset).

For more information, see *Resetting the Equipment if an Error Occurs* in Chapter 7.

The display in the **status line** includes:

- Information, warnings, and requests
- Error messages

The messages in the status line require different actions:

- Some messages let you continue working without confirmation or action.
- Some messages can be ignored several times until the system forces you to act.
- Error messages must be resolved so that the work can be continued.

All error messages are saved. You can view a list of the messages by touching **i**, then **Error list**. Below is an example of an error list.

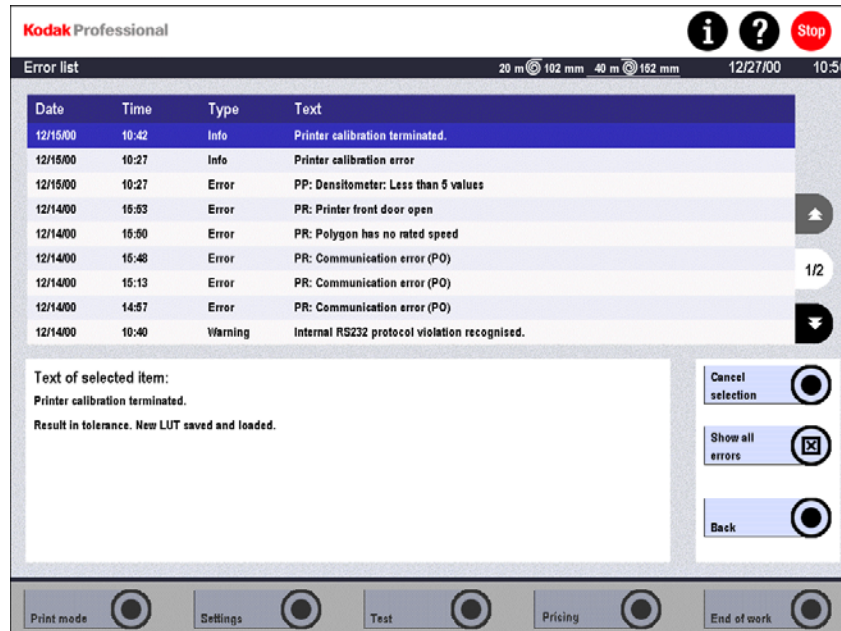

For more information, see *Correcting System Conditions*, Chapter 7.

Touch-sensitive Buttons

NOTE: Only one screen is active. It is not possible to open several windows at the same time.

The buttons in areas of the screen other than the information line (i, ? and **Stop**) change with the functions of the associated menu.

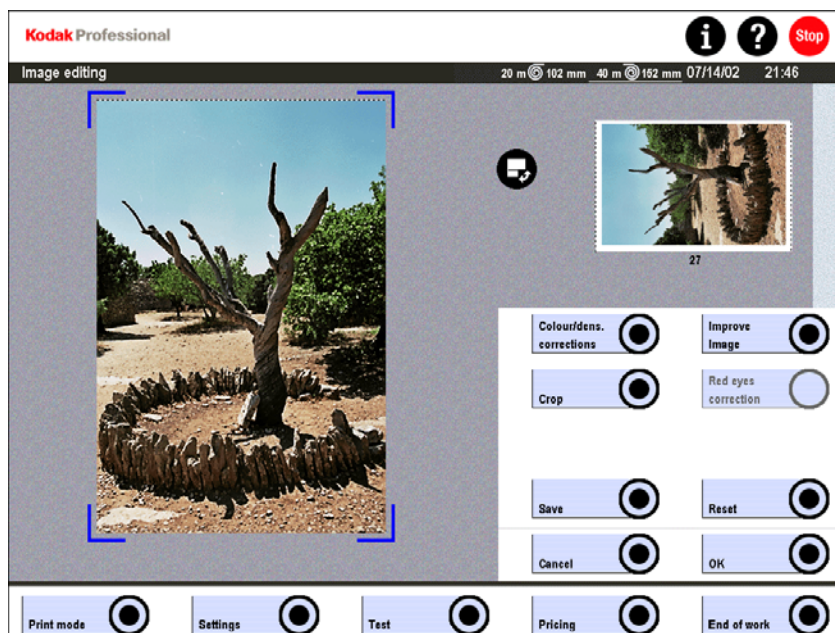

Touch the buttons to initiate the desired action, such as to:

- Select a submenu from the main menu bar
- Open a drop-down menu and make a selection
- Start, interrupt, or stop an action
- Select the desired configurations, images, and text in displayed selection windows
- Perform tests by way of the keyboard shown on the screen

All screens and associated buttons are explained in detail in this guide. Additionally, the online help feature, which you initiate when you press **?**, provides a detailed explanation for each screen.

Drop-down Menus

When you touch a button that lets you make a selection, a drop-down menu opens. If there are more entries than the display can show, arrow keys appear for scrolling.

For example, when you select a paper-width configuration, a drop-down menu appears with all configurations that you can select for the inserted paper width.

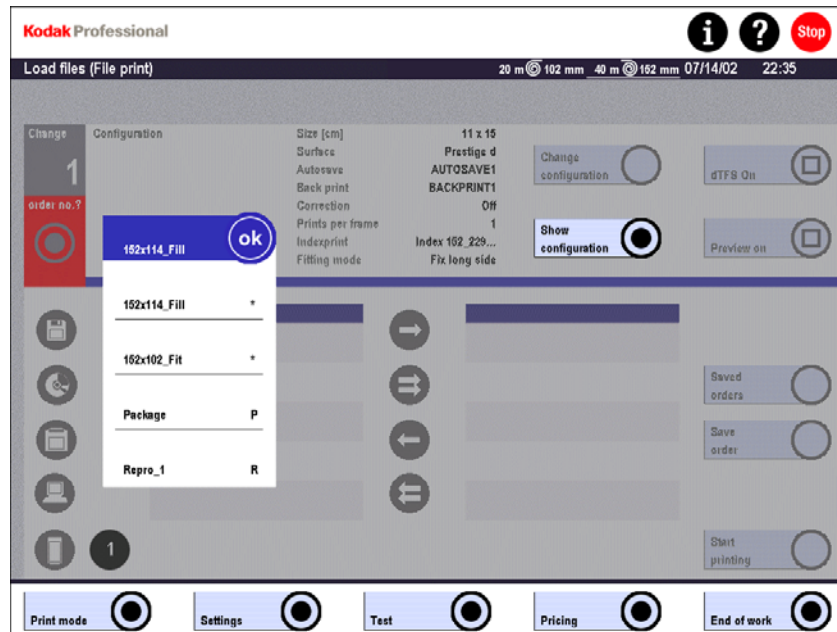

1. Select the desired configuration from the list.
2. Touch **OK**.

Pop-up Windows

Pop-up windows open on the active screen if you must make a confirmation or perform an action:

- A Reset pop-up appears when you must execute a reset to resolve an error.
- An Error pop-up appears when either incorrect (or inconsistent) entries or system errors occur. You must remove these errors before work can continue.

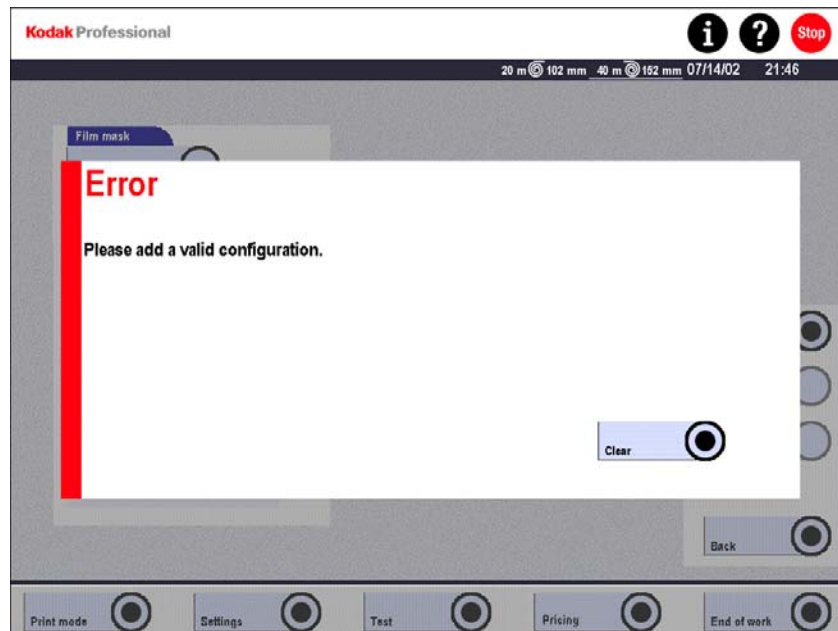

- A Warning pop-up appears if a risk of data loss occurs.

- An Info pop-up appears to provide additional status information.

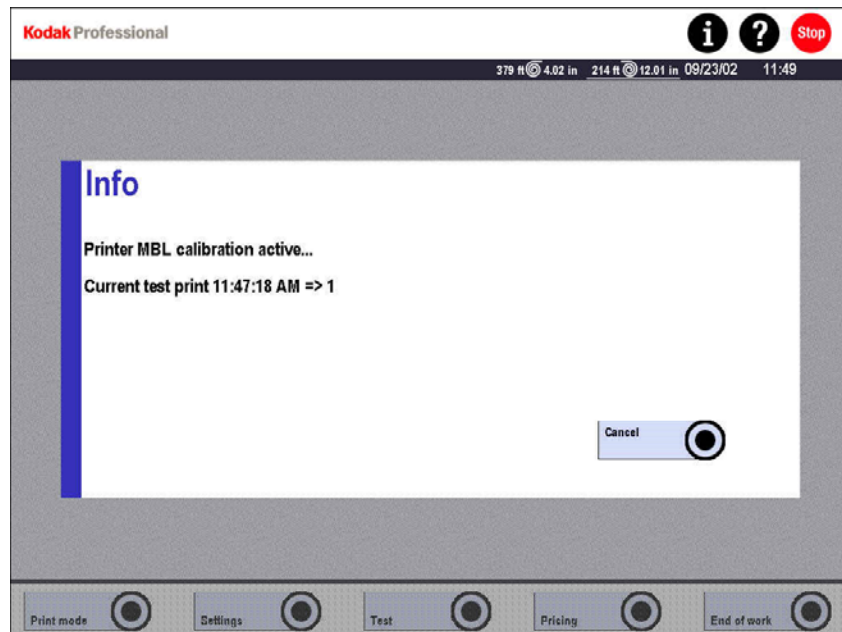

- A Query pop-up appears to let you avoid potential problems.

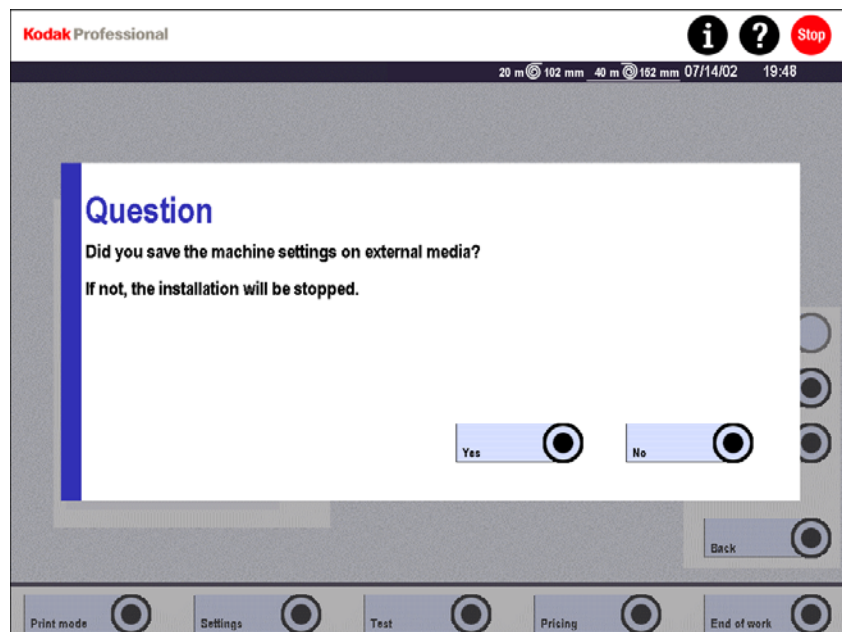

Input Screen

When you must enter text, numbers, or special characters, the Input screen opens.

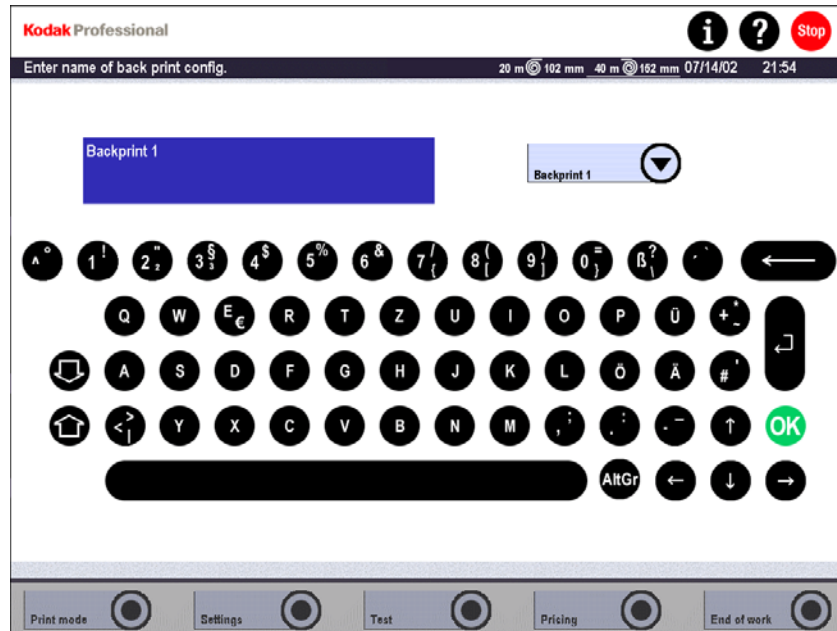

- The image of a keyboard includes national special characters in accordance with the selected keyboard allocation. (For the selection of the keyboard allocation, see *User Interface* in Chapter 4.) Touch a button to select the corresponding character.
- Typed characters appear in the blue field and in the button above the image of the keyboard to let you see how much of the text you enter will appear in the button when you select it from a drop-down menu.
- The **OK** button is the means for you to terminate your entry and return to the previous menu.

Numeric Keypad

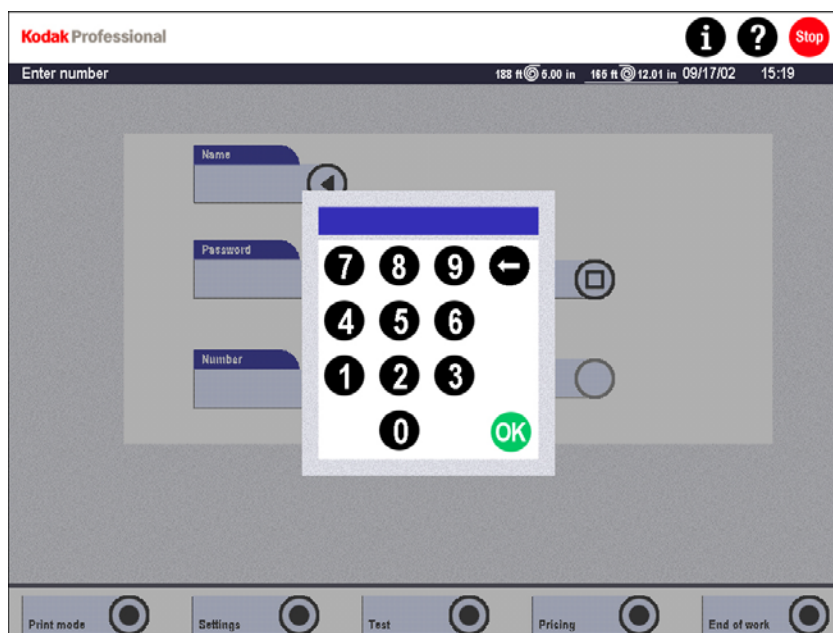

Use the numeric keypad in the display to enter the desired number and touch **OK** to confirm.

Menu Bar

The main menus are always accessible, except when either a pop-up window is open or the Help screen is open.

Menu buttons that appear gray indicate that the function is not available.

The structure of the menus is described in the next subsection, *Menu Overview*.

Menu Overview

Main Menu

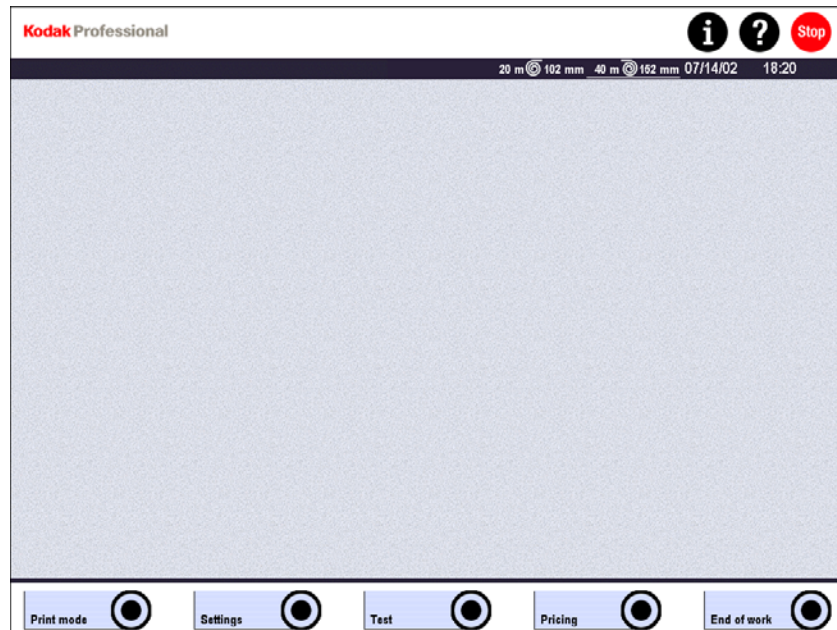

You can open the following main menus from the menu bar:

- Print mode
- Settings
- Test
- End of work

NOTE: Pricing is not available.

Other screens are available by pressing i and ?:

- Status information
- Help

All menus and associated screens are outlined on the following pages.

Print Mode Menu

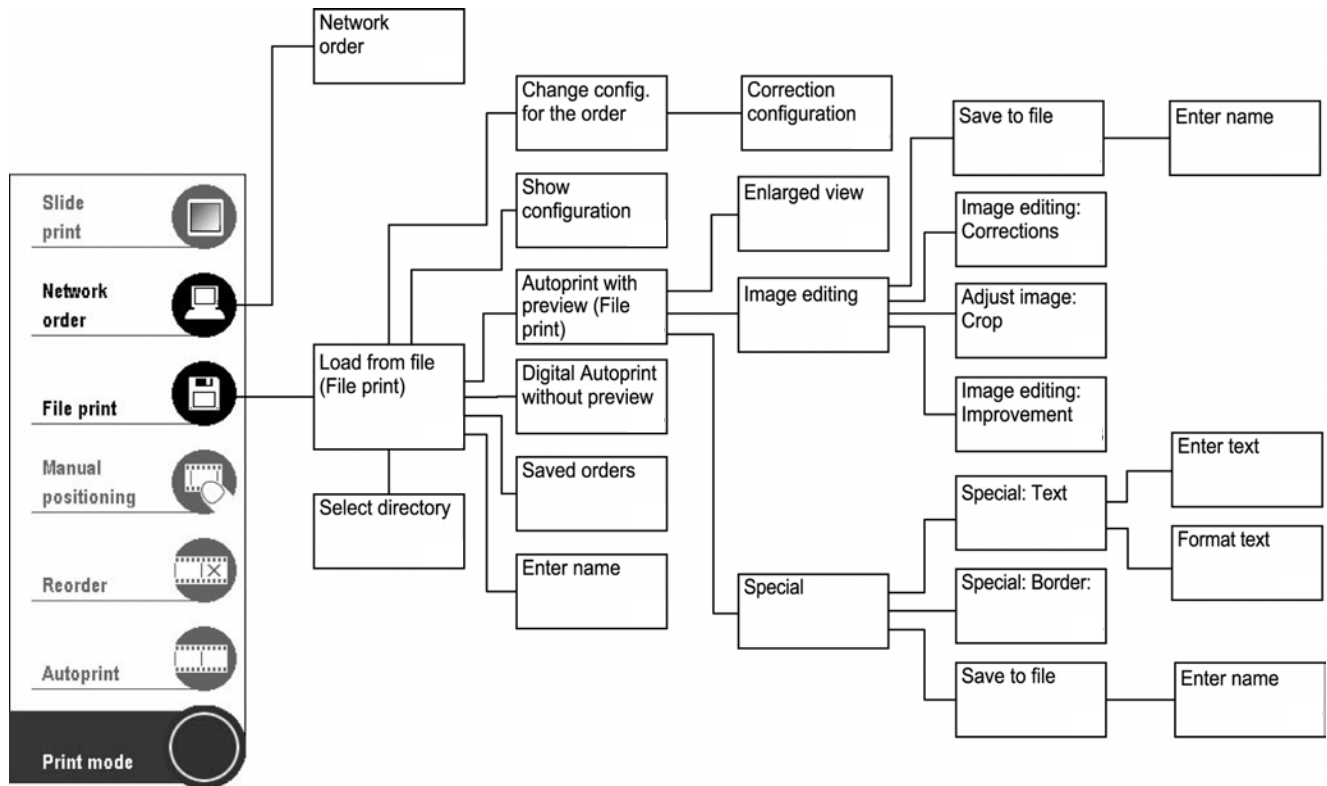

Settings Menu (without Machine Settings)

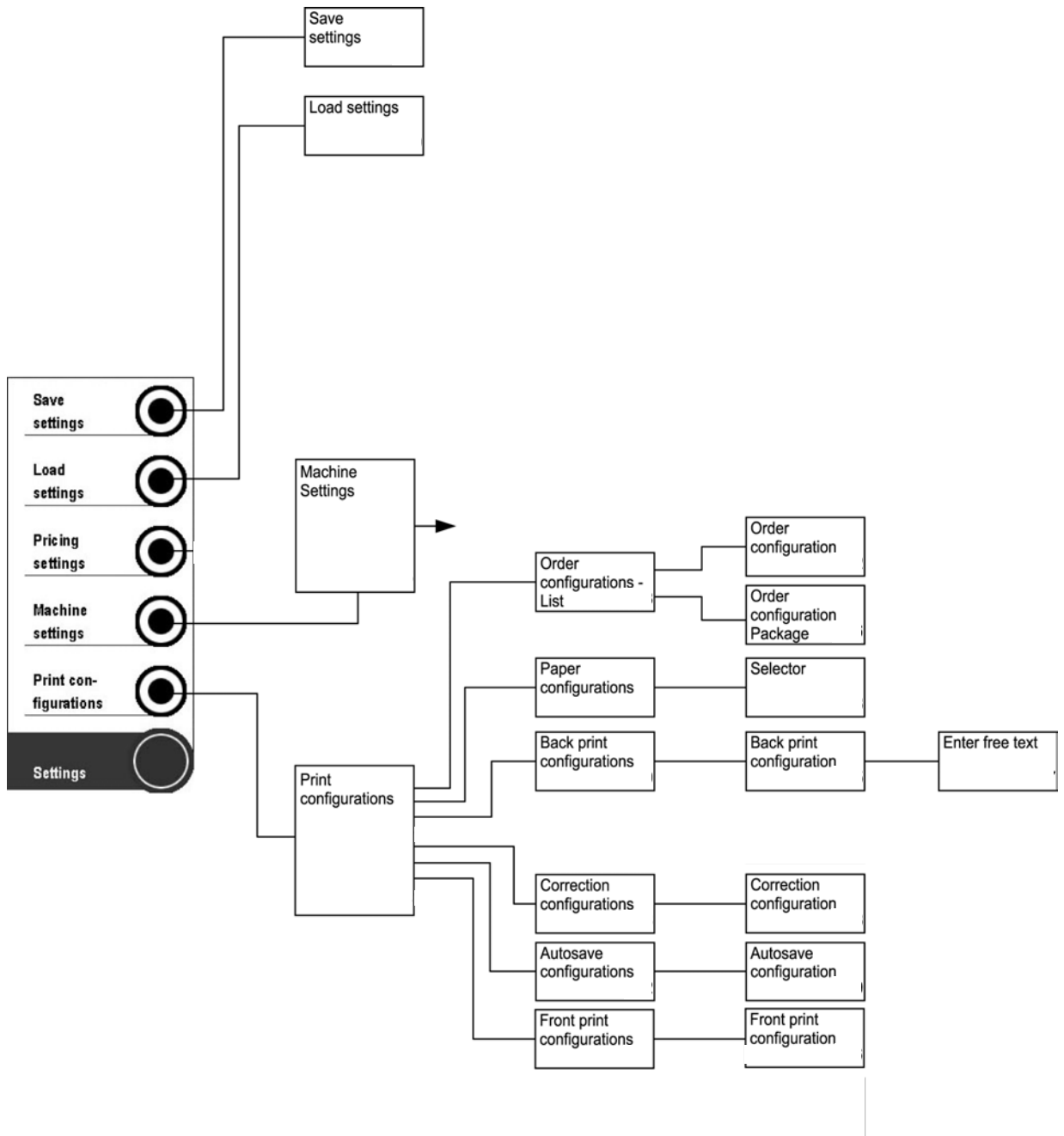

Settings Menu (with Machine Settings)

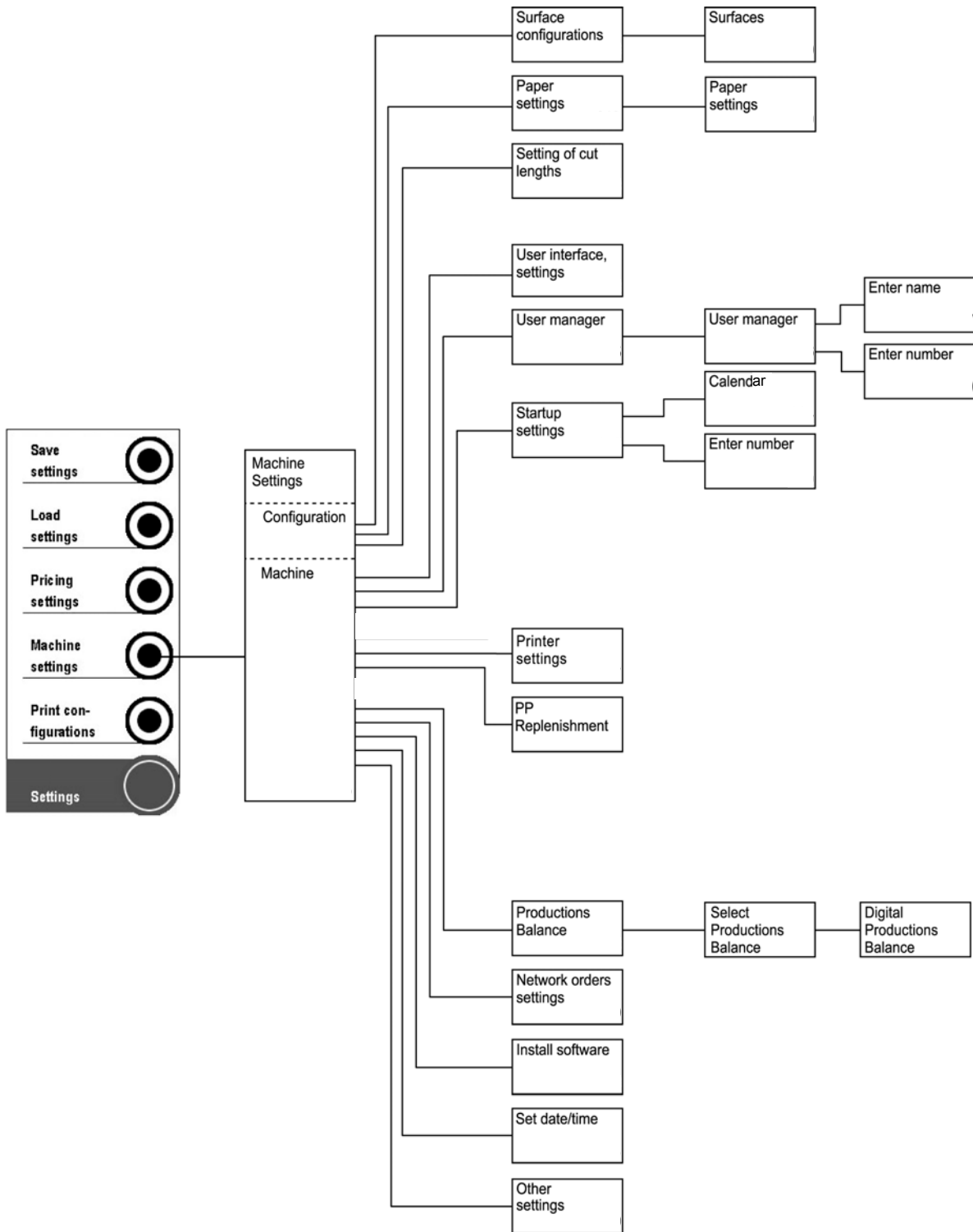

Test Menu

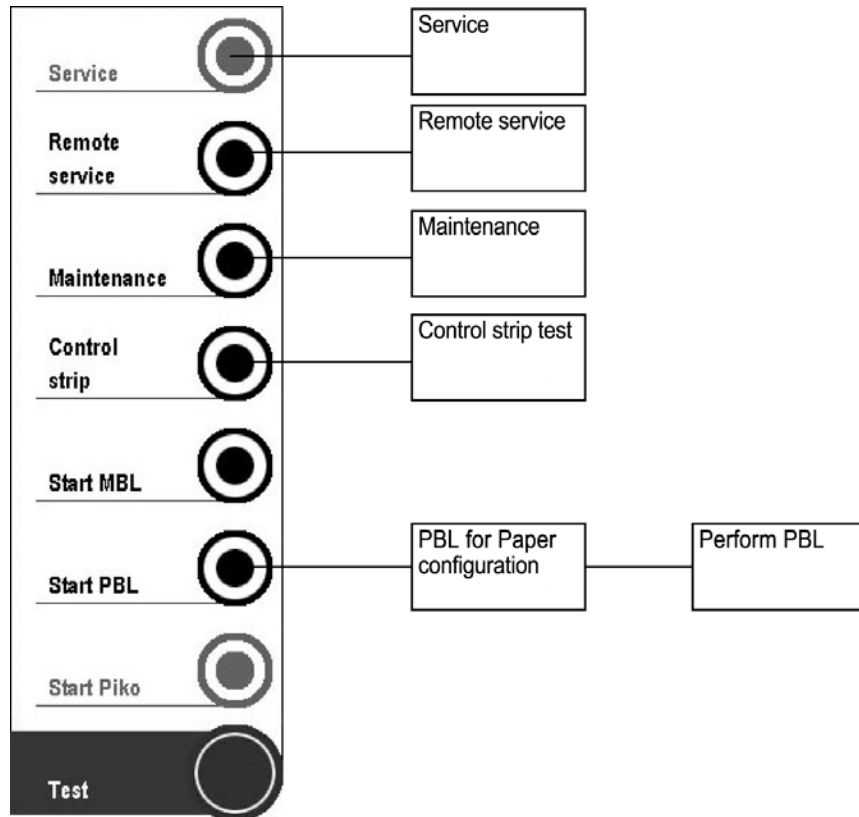

End of Work Menu

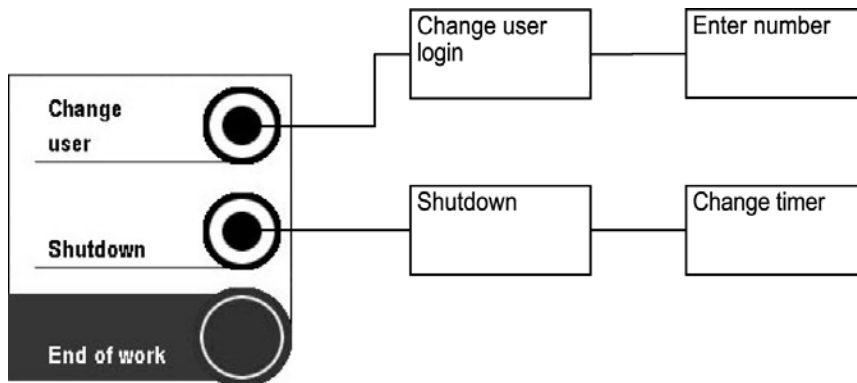

Status Information / Help Menus

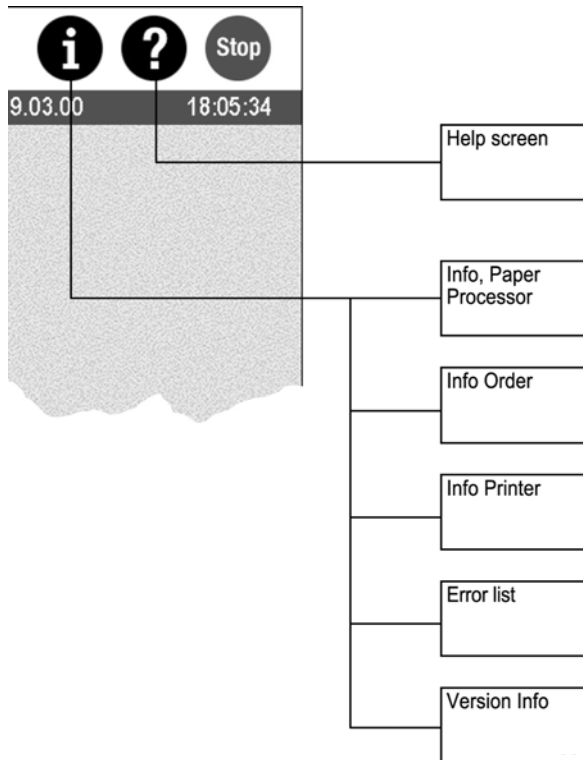

Additional Screens

These screens are accessible at any time. They are displayed when:

- Configurations can be modified, on demand with the button **Display Config**
- Text inputs (user names, back print text) are required, by touching the respective field
- Number inputs (order numbers, passwords) are required, by touching the respective field
- Errors occur that require resolution before work can continue
- You must make a decision

Info

You can access the **Info** screen from any other screen that has an **i** in the information area (see *Screen Structure* on Page 2-20).

The **Info** screen displays the operating hours of the scanner lamp and the laser. You can reset the counter for the operating hours of the scanner lamp in the **Test / Maintenance** menu.

For all other information, a separate screen opens.



- To open the **Info Printer** and **Info Paper Processor** screens, touch the black circle on the touch-screen for either the printer (left side of illustration) or the paper processor.
- To open the **Order Info**, **Version Info**, or **Error list** screens, touch the buttons with the respective names.
- To close the **Info** screen, touch **Back**.

NOTE: When an error occurs, the name of the module in question appears in red. Touch the button on the module to localize the error more precisely.

Info Printer

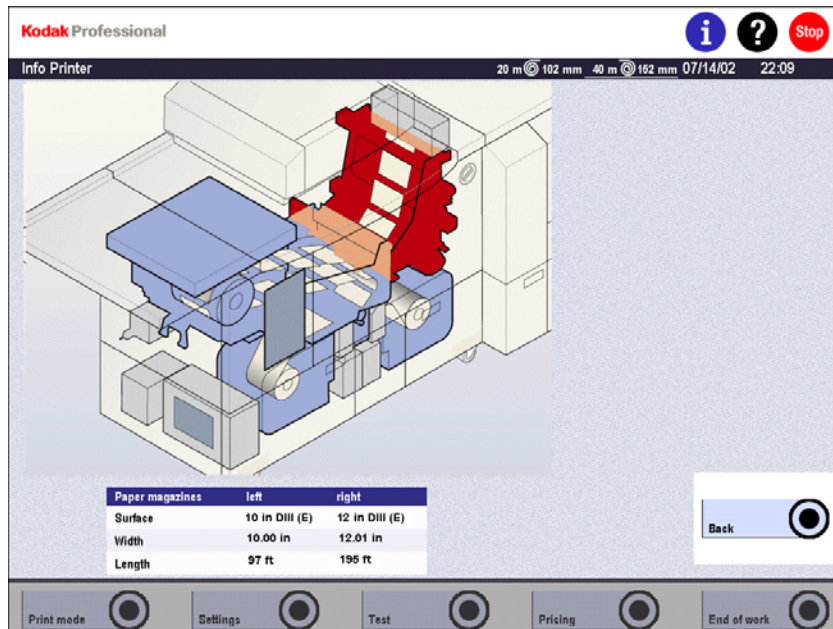

The **Info Printer** screen is a graphic representation of the paper transport and shows the number of prints at the individual stations in the printer. This screen also contains the width, surface, and residual length for each of the two paper magazines.

When an error occurs, the corresponding component of the printer is displayed in red.

To return to the main **Info** screen, touch **Back**.

Info Paper Processor

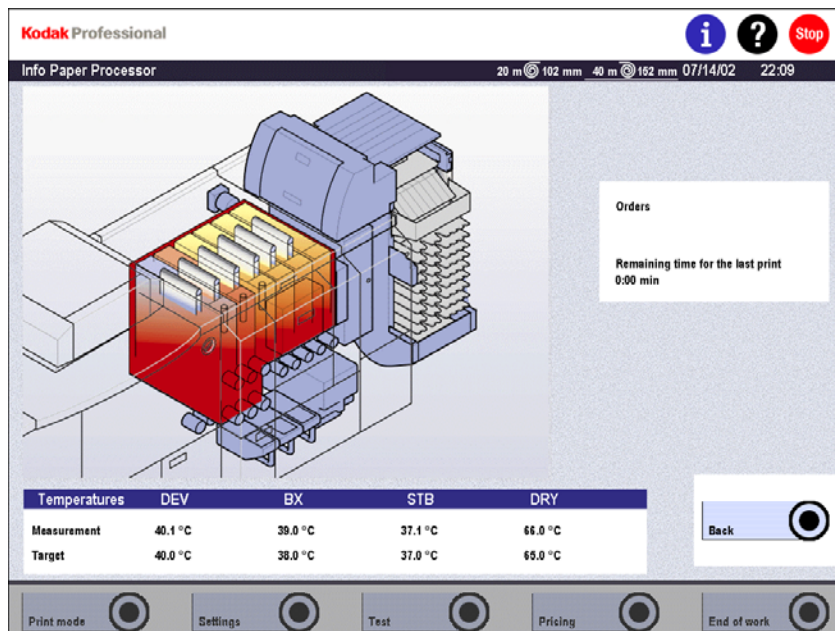

The **Info Paper Processor** screen is a graphic representation of the solution tanks and the dryer, and shows the number of prints currently in the processor. This screen displays:

- Order numbers for the orders in the paper processor
- Time remaining until the last print is exited
- Nominal and actual temperatures of the solutions and the dryer

When an error occurs, the corresponding component of the paper processor is shown in red.

To return to the main **Info** screen, touch **Back**.

Info Order

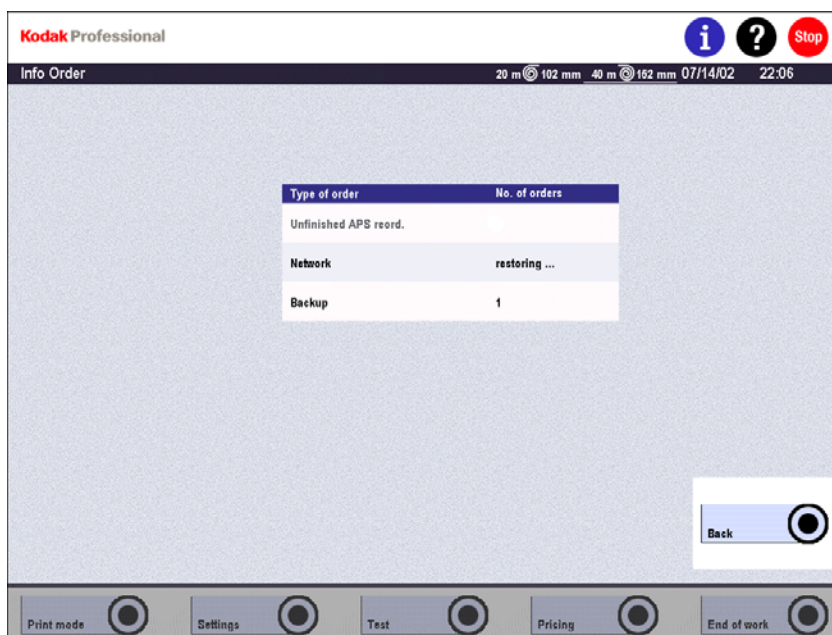

The Info Order screen displays the number of orders not yet printed, including network orders and orders stored for file prints (backup).

To return to the main **Info** screen, touch **Back**.

Version Info



The **Version Info** screen shows:

- Current versions of the installed software and firmware
- Serial number of the hardware
- License ID of the machine

To return to the main **Info** screen, touch **Back**.

Error List

All error messages shown in the status line are saved. Touch **i**, then **Error list** to view the error messages.

The list shows the error messages with the date and time of occurrence.



- Disable **Display all errors** if the error list only shows the errors encountered since the last start or reset.
- If the complete error message is not displayed in the error list, touch the message to display the complete text below the error list.
- To delete the message from the list, mark the message and touch **Remove selection**.
- Touch **Back** to return to the **Info** screen.

The error list and error removal are described in Chapter 7, *Correcting System Conditions*.

Help

You can access Help from every screen that has a ? in the information area (see *Screen Structure on Page 2-20*).

NOTE: For operations requiring significant computing time, the Help window is not displayed immediately. A pop-up window opens with the following options:

- Waiting or
- Cancel

Help text displays for the screen in which you touched ?. The display includes links to the Help texts.

To go to the relevant section in the Help text, touch the area concerned (such as the button, field, or list). Touch **↑** to go back.

Other buttons are provided on the right side of the Help window:

- **Help Index**
Touch a key word in the alphabetic listing to see the associated Help text.
- **Error Help Index**
This index is an alphabetic listing of the error messages.
- **Documentation**
Touch this button to view the Operator's Guide.
- Touch **Close** to return to the screen where you touched ?.

NOTE: In the Help window, **i** and **Stop** are accessible; however, the menu bar is not accessible.

Chapter 3 Chemicals

Contents

Contents	3-1
Preparation of Chemicals	3-3
Rinsing the Tanks.....	3-4
Mixing the Tank Solutions	3-5
Stabilizer	3-5
Bleach-Fix.....	3-6
Developer	3-6
Inserting the Chemical Filters.....	3-6
Installing the Racks and Bringing the Tank Solutions to Temperature	3-7
Preparing Replenisher.....	3-7
Other Operations to be Performed Prior to Production Start.....	3-8

Preparation of Chemicals

CAUTION: A risk of injury is possible if the wet section cover is unlocked (PUSH is pressed) unintentionally. The lock engages only in the vertical position.

To open the cover:

Carefully lift the cover until the lock engages.

To close the cover:

1. Support the cover with one hand.
2. Press the unlocking lever (PUSH) and carefully close the cover.

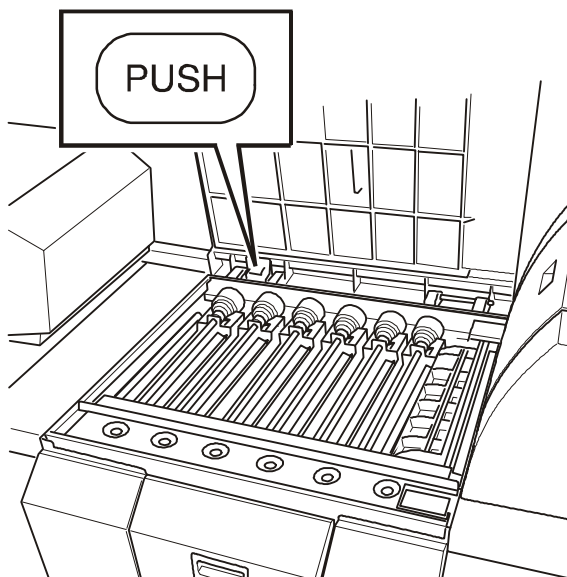

A water temperature of approximately 30°C (86°F) is recommended for the preparation of the individual tank fillings.

The chemicals can be mixed directly in the machine tanks.

CAUTION: To prevent contamination of the chemistry, always fill the tanks in the following order:

SB ⇒ BX ⇒ CD

Thoroughly rinse the containers used for the preparation with cold water after each preparation of a solution.

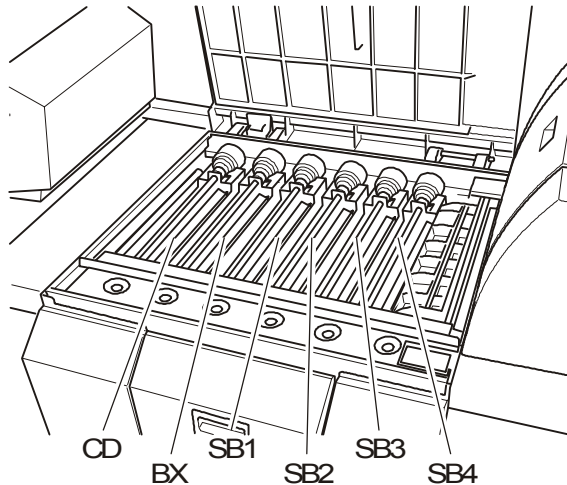

Rinsing the Tanks

1. Open the paper processor cover.
2. Fill the replenisher tank with water until the lower level sensors are covered to avoid the request for the connection of an EKTACOLOR Processing Cartridge.
3. Fill all machine tanks with hot water.
4. Let the equipment run for a short while to rinse the circulation system and remove any chemical residues.
5. Switch off the equipment and completely drain the cleaning water. Check that all drain valves are closed correctly.
6. Check the hose positioning. Make sure the hose has no:
 - Leaks
 - Sharp bends
 - Crimps
 - Air bubbles

Mixing the Tank Solutions

The instructions assume that you are mixing the fresh-tank solutions directly in the processor tank.

CAUTION: Use cold water when you mix solutions to prevent you from unnecessary exposure to fumes that can be released at higher temperatures.

Handle all chemicals carefully. When you mix solutions, wear goggles or a face shield, a protective rubber apron, and protective gloves made with either neoprene or nitrile rubber.

Clean protective clothing after use to remove any chemical residue that can cause contamination.

For more information about potential health hazards and safe handling of specific Kodak chemicals, see the label and the Material Safety Data Sheet (MSDS) for the chemical. Consult the MSDS for regional contact information.

MSDS copies are available at the Kodak website

<http://www.kodak.com/US/en/corp/hse/prodSearchMSDS.jhtml>

IMPORTANT: *To make sure that no chemistry splashes on the equipment, fasten the plastic covers from the accessory pack on the equipment.*

Open two KODAK EKTACOLOR Processing Cartridge 75 cartons and remove the four bottles from each carton.

When you remove the cap of a bottle, the label printed on the seal identifies the bottle as either the developer bottle (CD), one of the two bleach-fix bottles (BX-A or BX-B), or the stabilizer bottle (SB).

You will need:

- Two bottles of each part to make up the fresh-tank solutions
- A solution measuring device, such as a graduated cylinder that can accurately measure volumes up to 900 mL
- The ability to measure up to 10 L of water

For the developer you will need KODAK EKTACOLOR RA Developer Starter (CAT No. 102 6681).

Stabilizer

1. Add 10.3 L water to the first tank.
2. Add one-half the contents (approximately 72 mL) of one bottle of stabilizer concentrate (labeled **SB**).
3. Repeat Steps 1 and 2 for each of the three remaining stabilizer tanks.

The total volume for each tank is 11 L.

Bleach-Fix

You can mix the working bleach-fix tank directly from the two-part concentrates. Use two EKTACOLOR Processing Cartridge 75 units to supply the two bottles of each of the two concentrate solutions.

CAUTION: **Be careful to avoid contamination of the developer with bleach-fix.**

1. Add 12.7 L water to the tank.
2. Add the entire contents of two bottles of bleach-fix concentrate, Part A (labeled **BX-A**).
3. Add the entire contents of two bottles of bleach-fix concentrate, Part B (labeled **BX-B**).

The total volume in the tank is 18.0 L.

Developer

IMPORTANT: *To obtain good performance, it is important to take special care in mixing the developer tank.*

1. Add 15.9 L water to the tank.
2. Slowly add the entire contents of two bottles of developer concentrate (labeled **CD**).
3. Add 900 mL EKTACOLOR RA Developer Starter, CAT No. 102 6681.

The total volume in the tank is 18.5 L.

Inserting the Chemical Filters

1. Take the chemical filters out of the accessory pack.
2. Rinse the filters in water to remove loose fibers and attach the filters to the holders.
3. Put them in the appropriate tanks corresponding to the colored stickers. It may be necessary to turn the filter rods slightly so that the filters sit correctly.

Installing the Racks and Bringing the Tank Solutions to Temperature

When you fill the tanks with the new mixes, they will appear only partially filled. When you reinstall the racks in the tanks, the racks will displace more solution volume to fill the tanks.

1. Install each rack by slowly lowering it into the tank; the rack will displace additional volume to fill the tank and partially mix the solution.
2. When you have reinstalled all the racks, verify that all tanks are filled with solution.
3. Restore power to the equipment.
4. Starting the recirculation pumps will complete the mixing of the solutions.
5. Let the processor come up to operating temperature.

Tank	Temperature °C
Developer	40.0 +/- 0.3
Bleach-Fix	38 +/- 2
Stabilizer	37 +/- 3

Preparing Replenisher

1. Fill 7 L (1.8 gal) of water in the Astor tank (1).
2. Fill the water tank until the upper one of the two float sensors is activated or the overflow indicator sticks out of the tank.
3. Prior to the first paper transport, water must be used to wet the foam rollers of the squeegee unit (2). Otherwise the wet paper could stick to the dry rollers.

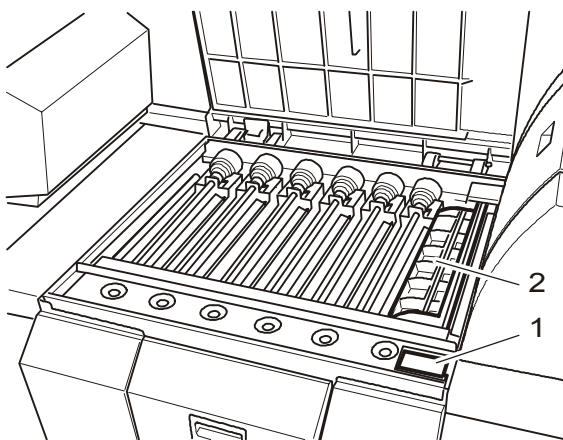

4. Put the EKTACOLOR Processing Cartridge in the docking station with the sticker facing up.
5. The preparation of the replenishers starts as soon as the docking station is closed. During this procedure, the door is locked mechanically and the LED on the left side of the docking station illuminates steadily.

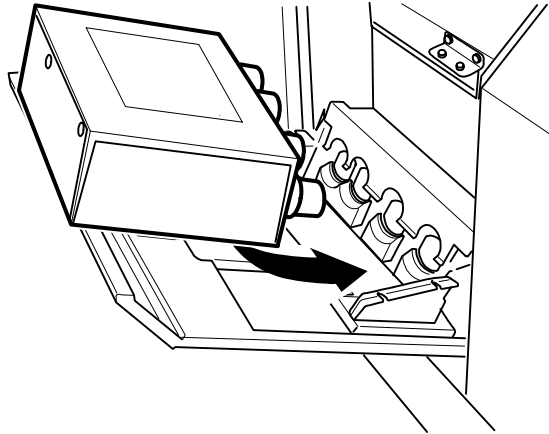

IMPORTANT: *There should always be a cartridge in the docking station to reduce oxidation. Once the LED is turned off, the cartridge may be removed and replaced by a full one. Alternatively, the empty cartridge may remain in the machine until you get a message to insert a new cartridge.*

The replenishers are mixed automatically by the integrated electrically driven mixers.

A preparation is sufficient for about 75 m² (807 ft²) of color negative paper, equivalent to approximately 1400 8 x 10-in. (20 x 25-cm) prints.

Other Operations to be Performed Prior to Production Start

1. Set the reference values.
See *Paper Processor Settings* in Chapter 4.
2. Adjust the equipment to the operators' needs (national settings) and to the production requirements (configurations).
See *Settings*, Chapter 4.
3. Test the chemistry.
See *Testing the Paper Processor* in Chapter 5.
4. Calibrate the machine.
See *Tests*, Chapter 5.

Chapter 4 Settings

Contents

From the Order Receipt to the Finished Print	4-3
Administrator	4-3
Operator	4-4
Preparation of the Print Configuration.....	4-5
Settings.....	4-11
Entering Names.....	4-12
Entering Numbers.....	4-13
Machine Settings	4-14
Types of Settings.....	4-14
Configuration	4-14
Machine	4-15
Defining Surfaces	4-16
Defining Paper Settings.....	4-17
Coding the Paper Magazine.....	4-19
Defining Cut Lengths.....	4-20
User Interface	4-21
User Administrator: Defining Users and User Rights.....	4-22
Startup: Defining the Start Time / Standard User (Timer).....	4-25
Calendar: Defining Off Days.....	4-26
Installing the Software	4-27
Printer Settings	4-28
Paper Processor Settings.....	4-29
Setting the Replenishment Rates.....	4-29
Replenishment Rates	4-30
Production Balance – Digital	4-30
Impact.....	4-32
Sharpness of Edges	4-33
Saturation	4-33
Sharpness of Grain.....	4-34
Detail Contrast.....	4-34
Corrections YMCD.....	4-34
Digital Order Settings	4-35
Remote Order File Print.....	4-35
Remote Order Autosave.....	4-36
Network Orders	4-36
Other Settings.....	4-38

Print Configurations	4-40
Creating, Editing, and Deleting Configurations.....	4-42
Creating a New Configuration.....	4-42
Creating a New Configuration Based on an Existing One.....	4-42
Editing a Configuration.....	4-43
Deleting a Configuration	4-43
Paper Configurations	4-44
Creating a Paper Configuration	4-44
Backprint Configurations.....	4-46
Correction Configurations	4-49
Autosave Configurations.....	4-51
Front Print Configurations.....	4-55
Order Configurations.....	4-57
Creating a Single Configuration	4-59
Creating a Package Configuration.....	4-60
Reproduction.....	4-61
Configuration Types in the Order Configuration List.....	4-62
Black-and-White and Sepia Prints	4-62
Defining a Configuration as the Standard Configuration	4-63
Saving and Loading Settings and Configurations	4-64
When to Save Settings	4-64
Procedure.....	4-64
Load Settings	4-65

From the Order Receipt to the Finished Print

Administrator

Administrator actions Definition of settings, configurations, users	Initiated using the following buttons
Settings for the automatic Startup by the timer: start times, first user, calendar with off-days and company holidays	Settings Machine settings Startup
Configuration settings: They are used as the basis for the print configuration. Definition of paper widths and surfaces and corresponding coding of the paper magazines, definition of cut lengths	Settings Machine settings Surface / Paper settings Cut lengths
Machine: Country-specific settings, machine settings, production balance, communication with other equipment (remote orders).	Settings Machine settings User interface Printer (MBL retries) Paper Processor (replenishment rates) Productions balance digital Network orders
Creating a user with password, language, user rights	Settings Machine settings User manager
Creating sub-configurations	Settings Print configurations Paper Backprint Correction Autosave Front print
Combining sub-configurations to order configurations: Single, Package	Settings Print configurations Order
Creating a backup copy of the settings and configurations	Settings Save settings

Operator

Operator actions Logon, preparing the equipment, test, and order editing	Button or Action
User Logon	Shutdown Change user Select a name for the operator Enter the Password Touch Login
Preparing the RP 30 Laser Printer for an order	Prepare paper magazines (insert paper, code magazine) and insert them
Testing the paper and the equipment: IMPORTANT: Use MBL paper for the 1st PBL.	Test PBL MBL
Order handling: – with preview, or – with preview and image edition (only for File print)	Print modes Network order File print

Preparation of the Print Configuration

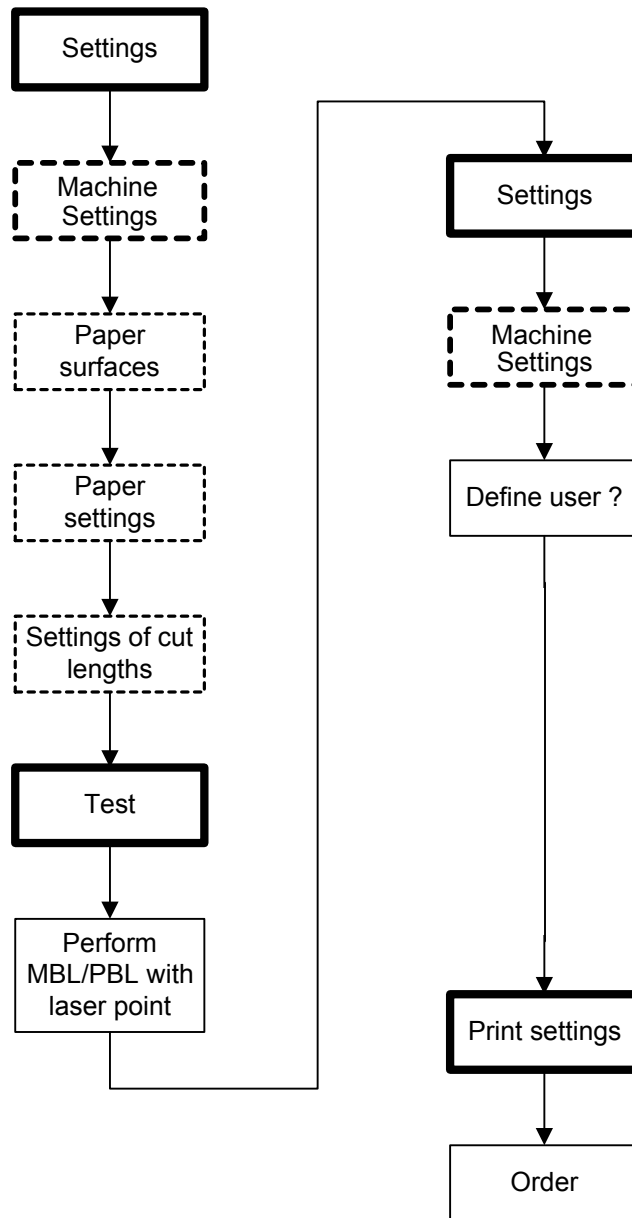

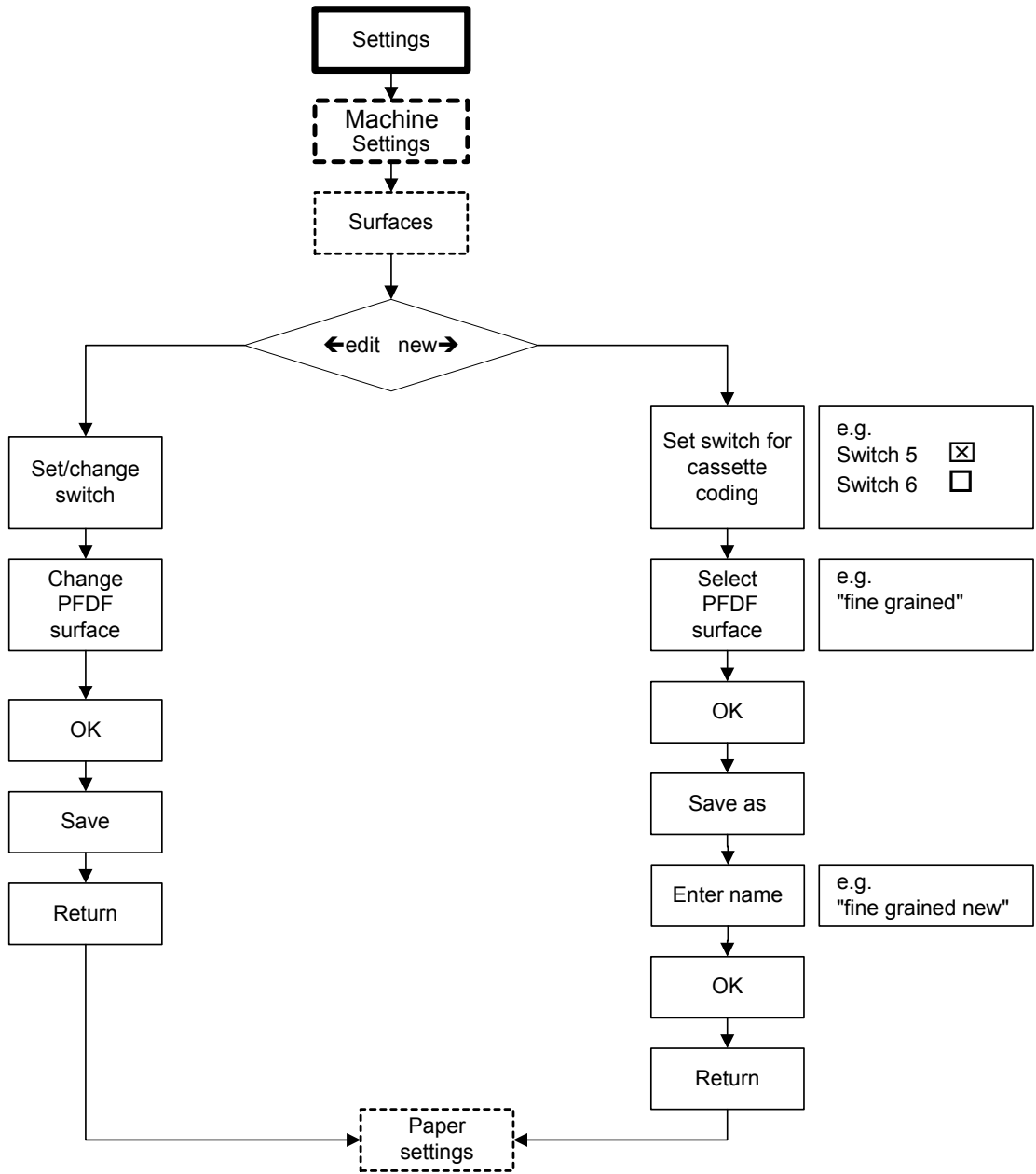

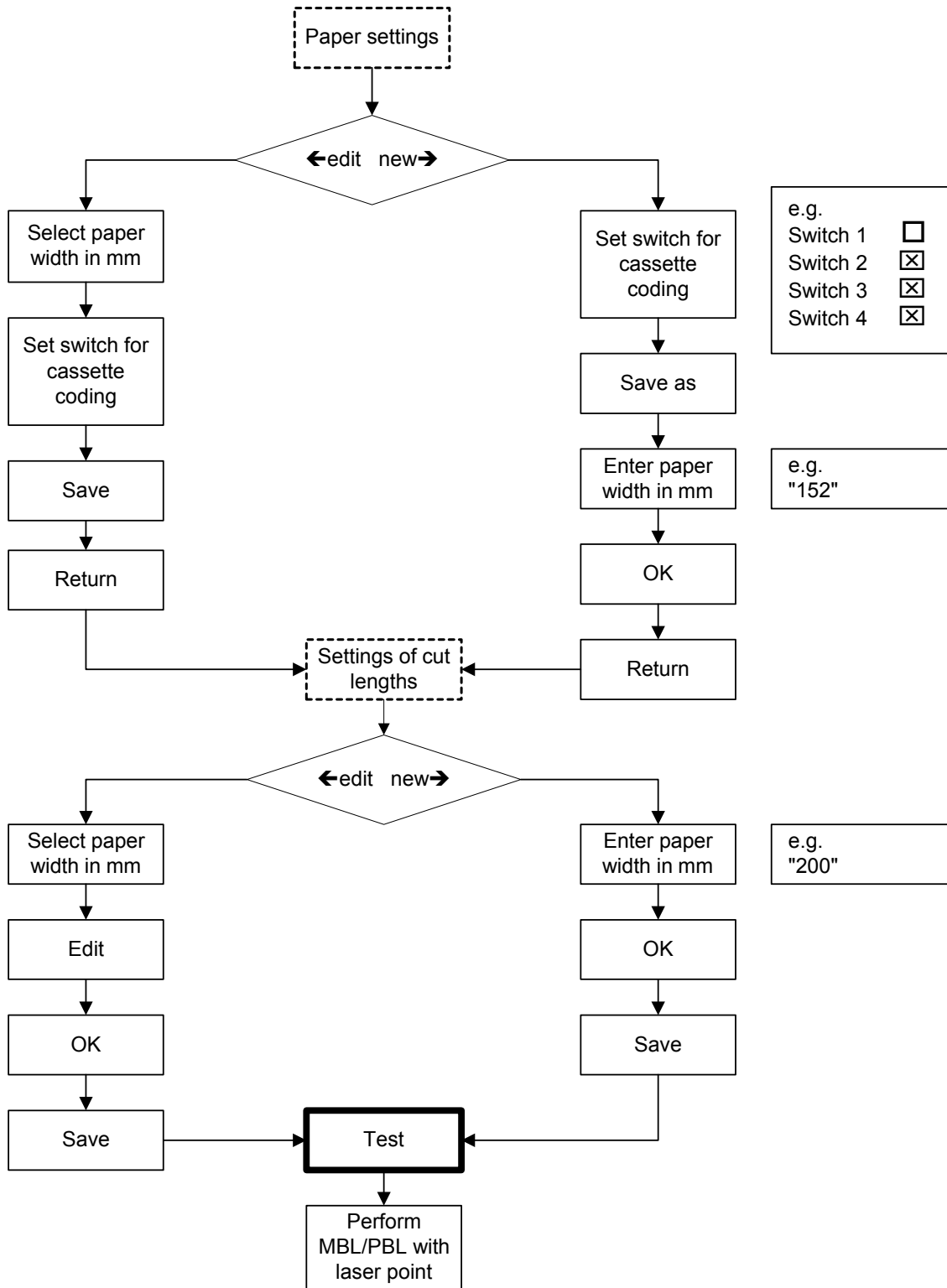

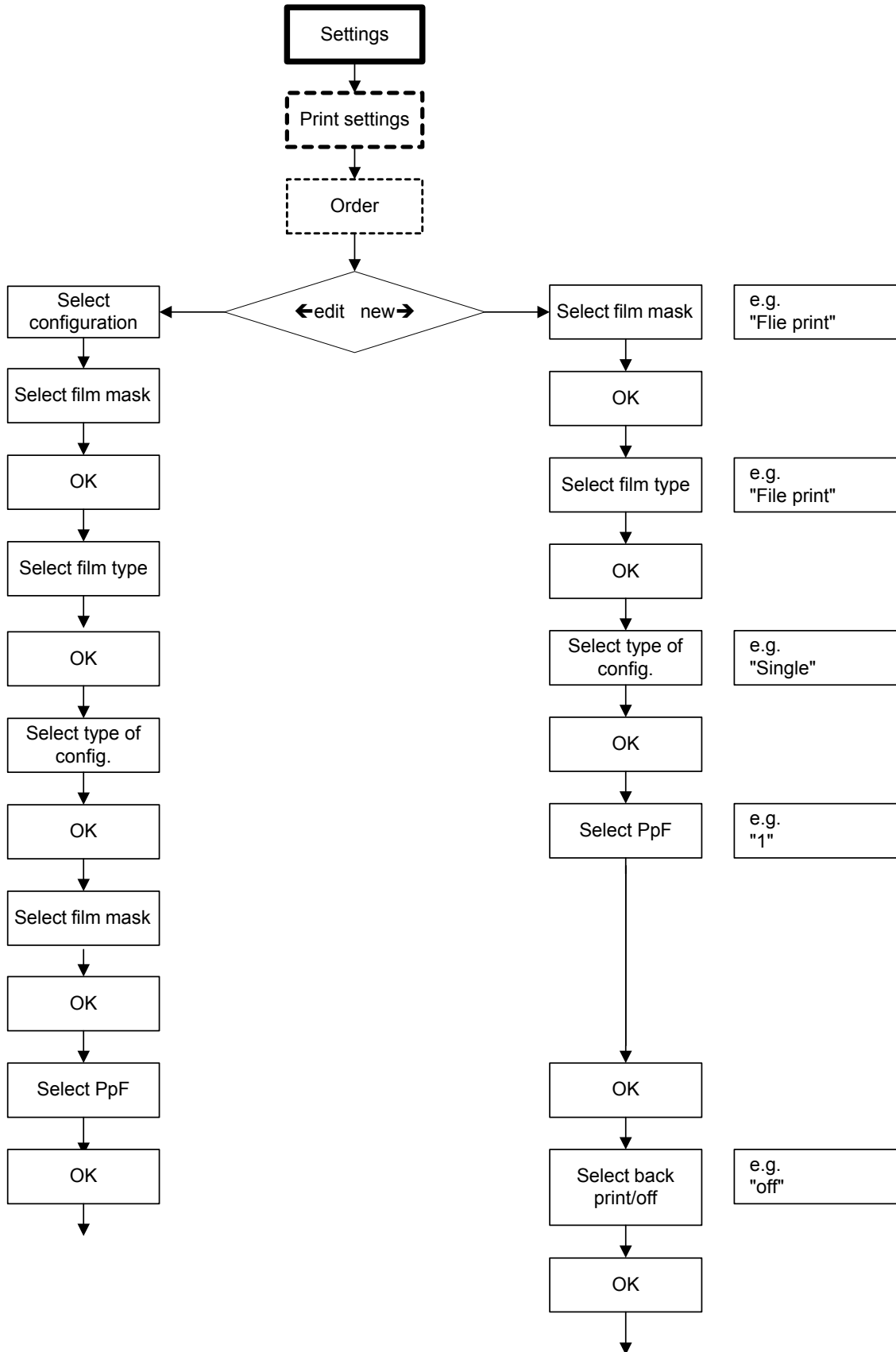

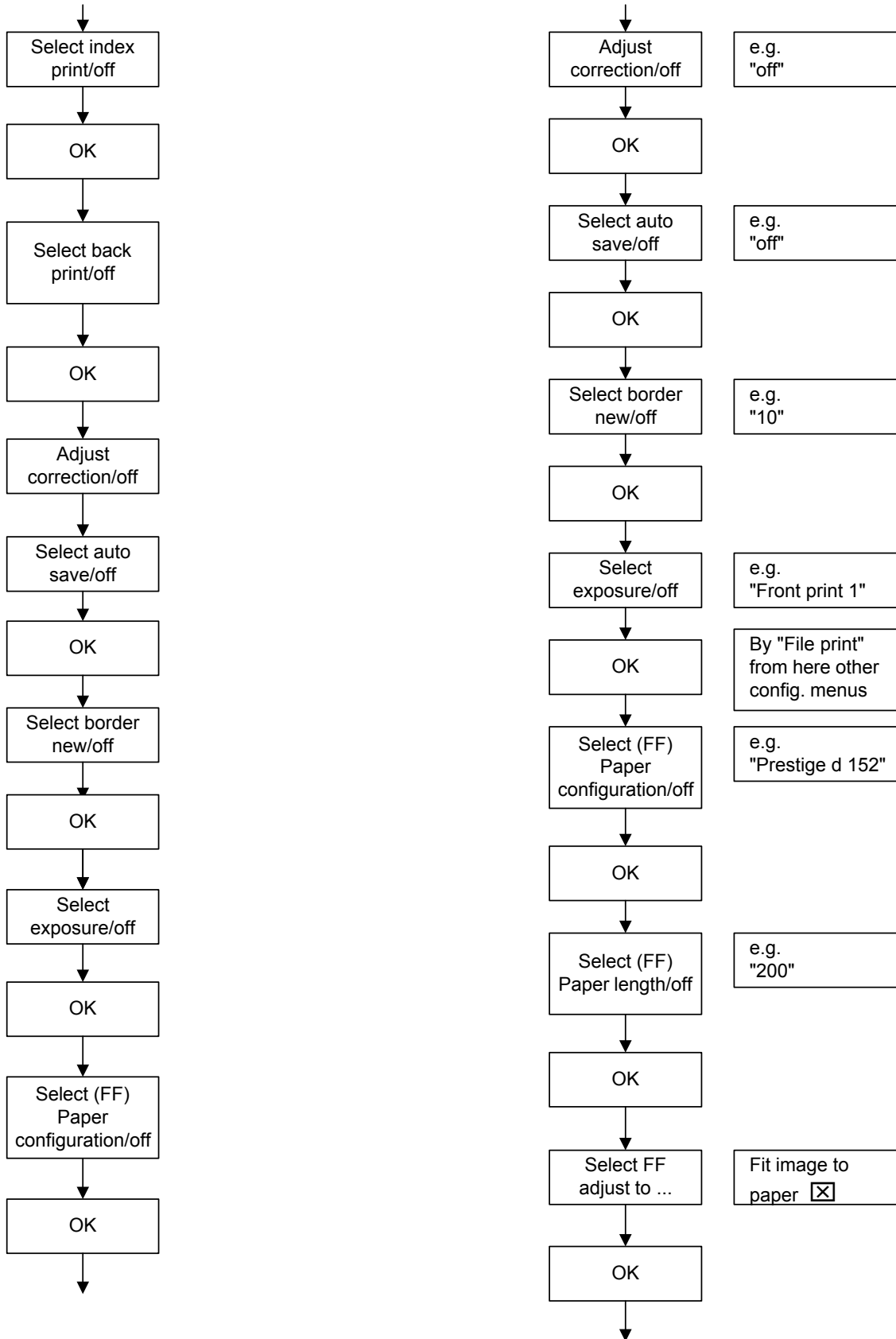

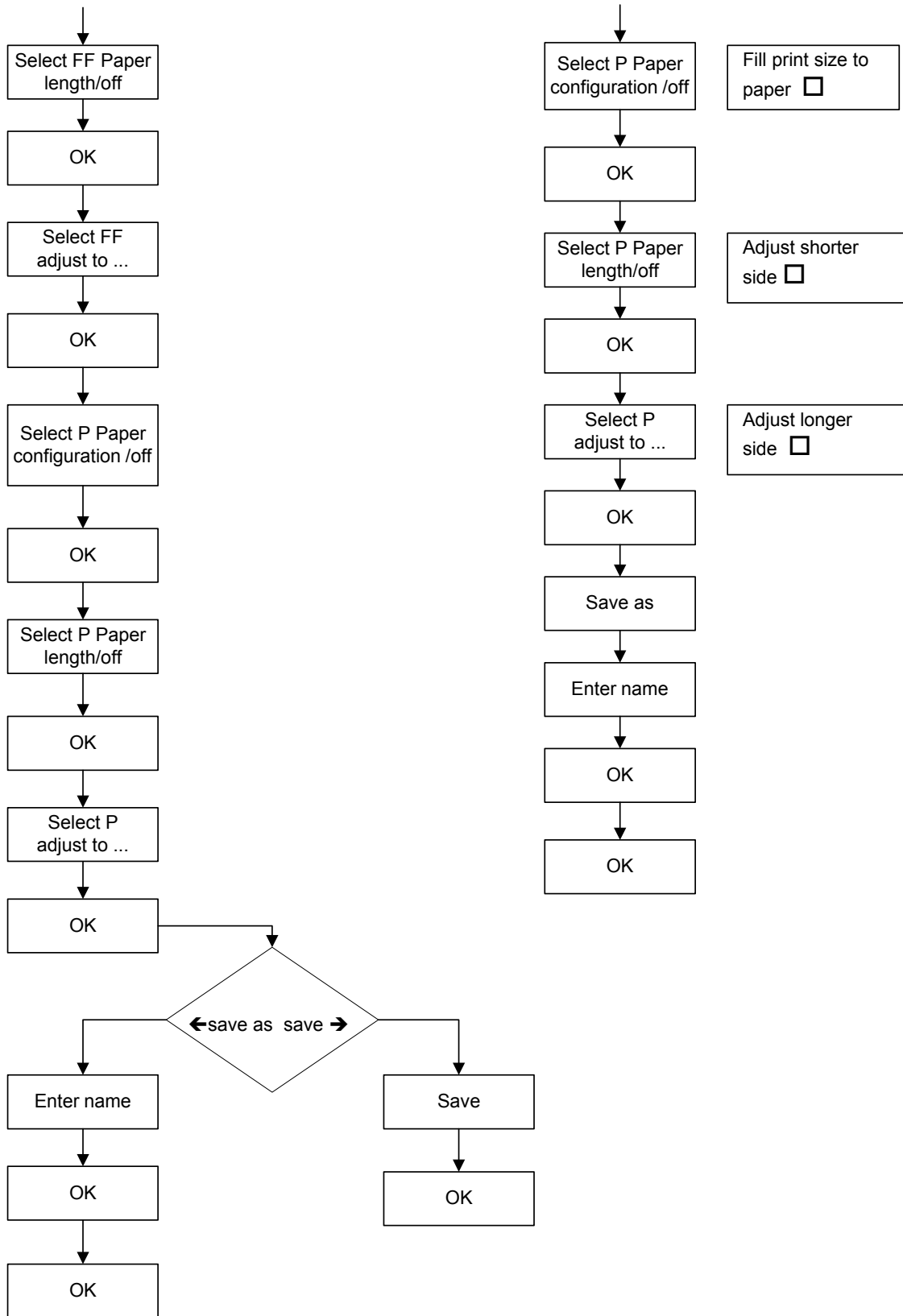

Settings

Settings can only be modified if there is no paper in the transport of the printer and paper processor. The **Settings** menu item is disabled as long as paper runs through the equipment.

When all prints of the current order are in the paper processor, you can touch **Stop** to stop the running operation. The **Settings** menu will then be available.

To open the **Setting screen**, touch **Settings** on the menu bar.

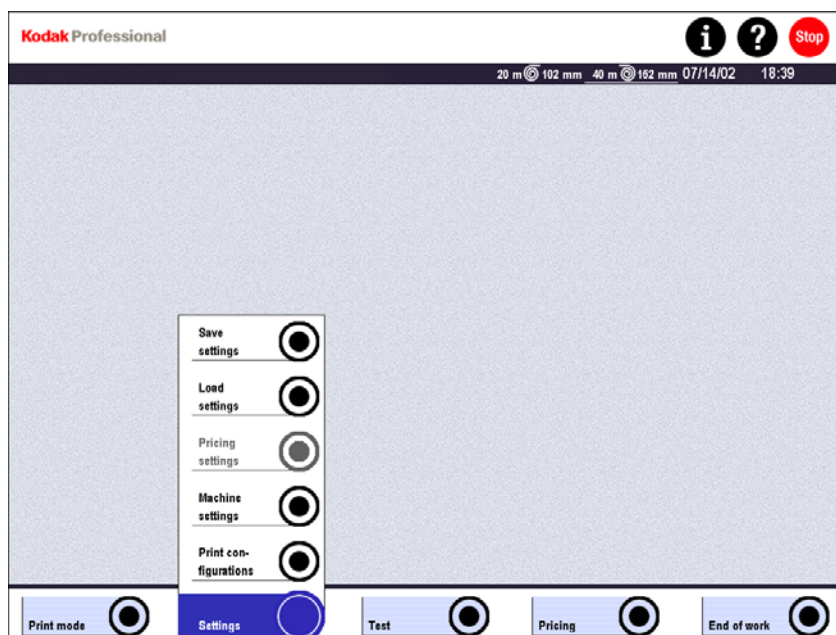

The following options are available:

- **Print configurations**
For creating print configurations for production, with all associated sub-configurations.
- **Machine settings**
For adjusting the equipment to user needs and lab requirements.
- **Save settings**
For saving all machine settings and print configurations.
- **Recover settings**
For reloading saved settings and/or configurations.

Entering Names

If entry of names is required, the **Input screen** opens automatically.

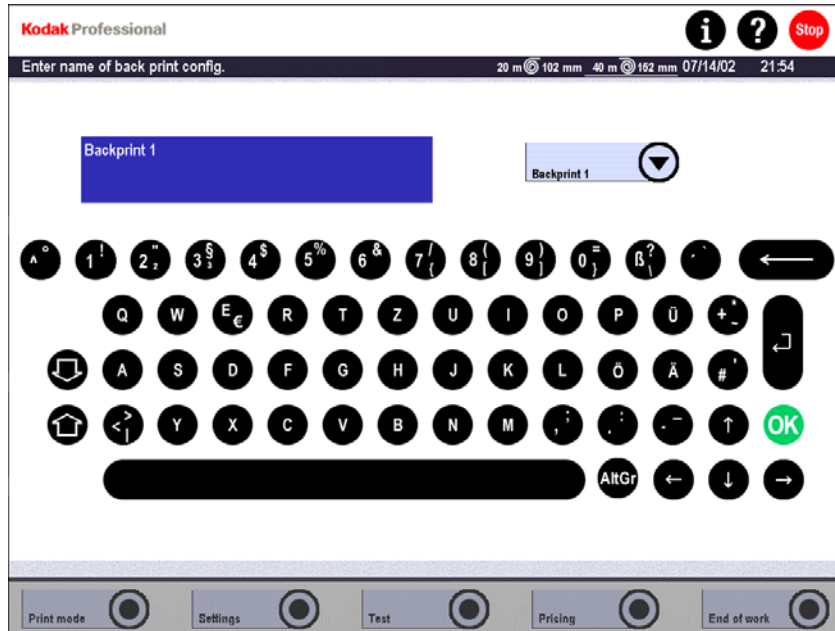

Names of configurations have a maximum length of 30 characters. Special characters are possible, with the exception of quotation marks.

Characters that are typed appear in the blue field and in the button above the image of the keyboard. This lets you see immediately how much of the entered text will appear in the button when you select it from a list or drop-down menu.

Press **OK** to enter the displayed text for the active screen.

Entering Numbers

If entry of numbers is required (the numeric user password, for example) the numeric keypad opens automatically.

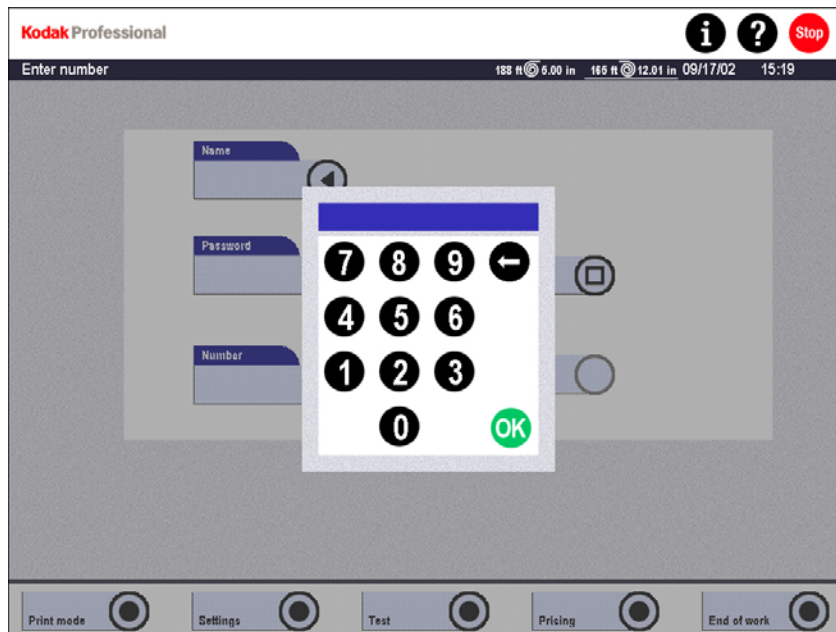

Enter the value and press **OK**.

Machine Settings

Types of Settings

To open, touch:

- **Settings**
- **Machine settings**

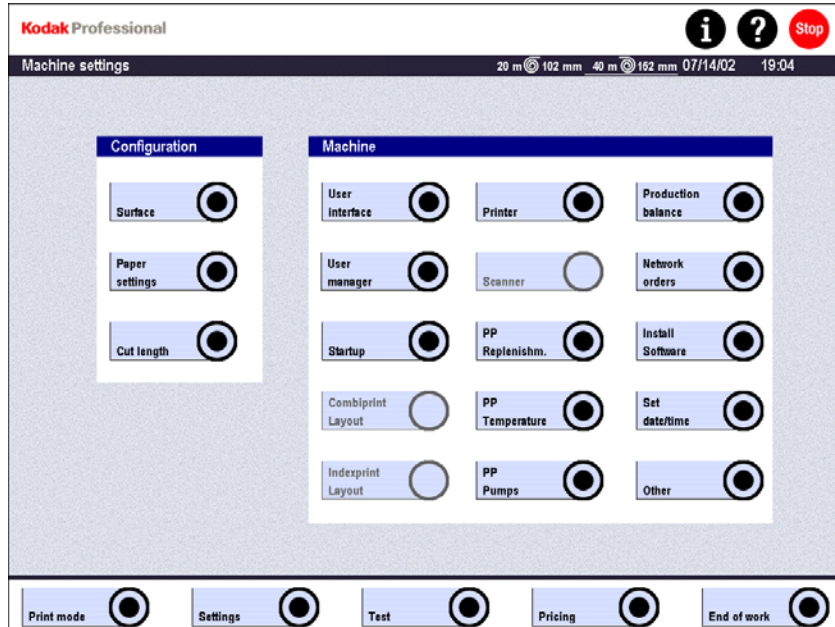

The machine settings are divided into two sections: **Configuration** and **Machine**. The configuration settings are saved and loaded together with the print configurations.

Configuration

- **Surface and Paper settings**
Set the switches according to the paper magazine coding for the surfaces (5-6) and the paper widths (1-4).
- **Cut length**

Machine

- **User interface** for the national settings
- **User manager** to create users with name, password, and rights of access
- Settings for the automatic **Startup**, like workdays with start times / first user, calendar (holidays, company holidays)
- Settings for the printer and paper processor
- Settings for the printer and paper processor
- **Production balance**
Impact, sharpness - edges, saturation, sharpness - grain, detail contrast, color / density corrections
- **Network orders**
Settings to receive and send remote orders (file print / Autosave) and network orders
- **Install Software**
Updating of system software
- **Set date/time**
- **Other settings**
Lab name/ID for the backprint, settings for the automatic end of order and the automatic order number, and settings to prevent excess prints in case of input errors.

Defining Surfaces

1. Touch:
 - **Settings**
 - **Machine settings**
 - **Surface**
 - **New**

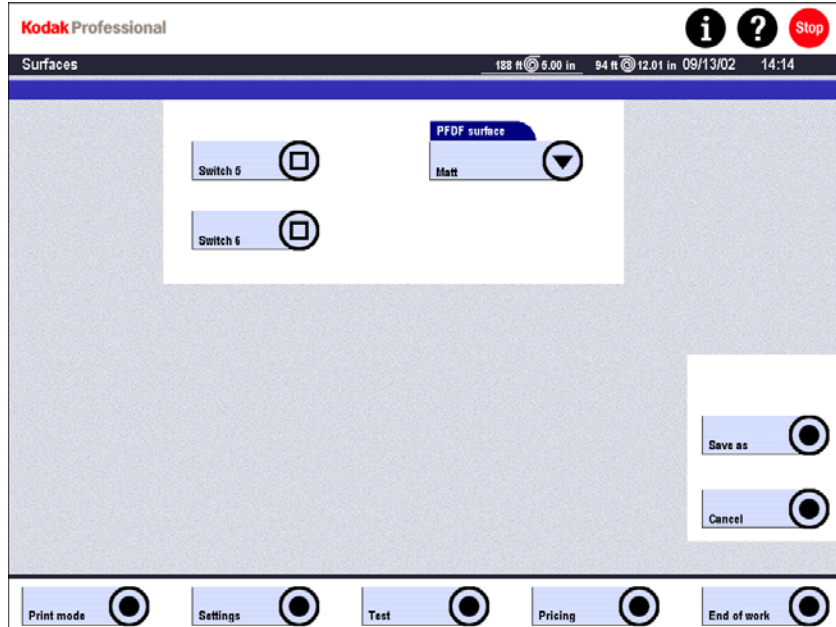

2. Select **PFDF surface**.
This is a list of the standard PFDF surfaces (important for network orders), such as Glossy (F), Matte (N), or Lustre (E).
3. Activate **Switch**.
The switches 5 and 6 define the name of the paper surface. (See *Coding the Paper Magazine* on Page 4-19.)
4. Select **Save as**.
Enter the name of the new surface configuration. **Save** is only displayed if the screen was opened using **Edit**.

Defining Paper Settings

1. Touch:
 - **Settings**
 - **Machine settings**
 - **Paper settings**



2. Touch **New** to create a new paper width
3. Select a configuration from the list and click **Edit**.

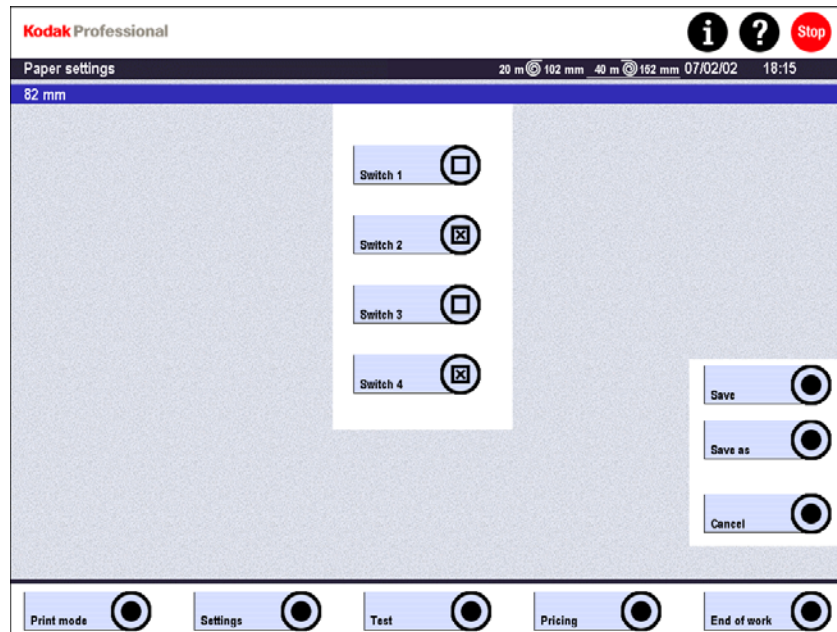

4. Activate the appropriate **Switches**.
The switches 1 to 4 define the paper width. (See *Coding the Paper Magazine* on the next page.)
5. Select **Save as**.
Enter the name of the new paper setting. **Save** is only displayed when the screen was opened using **Edit**.

The total number of paper widths usable without modification is 16. A maximum of four different surfaces can be used in the same way for all widths.

Coding the Paper Magazine

The paper magazine is coded for the paper width (1-4) and the surface (5-6) in use. The meaning of the coding is described below.

- Slide closed
 Slide open

Paper Width	Width Indicators				Surface Indicators	
	1	2	3	4	5	6
3.25 inch (82 mm)	<input checked="" type="checkbox"/>	<input type="checkbox"/>	<input checked="" type="checkbox"/>	<input type="checkbox"/>		
3.50 inch (89 mm)	<input checked="" type="checkbox"/>	<input type="checkbox"/>	<input checked="" type="checkbox"/>	<input checked="" type="checkbox"/>		
3.75 inch (95 mm)	<input type="checkbox"/>	<input checked="" type="checkbox"/>	<input checked="" type="checkbox"/>	<input checked="" type="checkbox"/>		
4.00 inch (102 mm)	<input checked="" type="checkbox"/>	<input checked="" type="checkbox"/>	<input checked="" type="checkbox"/>	<input type="checkbox"/>		
4.75 inch (120 mm)	<input checked="" type="checkbox"/>	<input checked="" type="checkbox"/>	<input type="checkbox"/>	<input checked="" type="checkbox"/>	GLOSSY	<input checked="" type="checkbox"/> <input type="checkbox"/>
5.00 inch (127 mm)	<input checked="" type="checkbox"/>	<input type="checkbox"/>	<input type="checkbox"/>	<input checked="" type="checkbox"/>	MATTE	<input checked="" type="checkbox"/> <input checked="" type="checkbox"/>
6.00 inch (152 mm)	<input checked="" type="checkbox"/>	<input type="checkbox"/>	<input type="checkbox"/>	<input type="checkbox"/>	CUSTOM1	<input type="checkbox"/> <input checked="" type="checkbox"/>
6.50 inch (165 mm)	<input type="checkbox"/>	<input checked="" type="checkbox"/>	<input checked="" type="checkbox"/>	<input type="checkbox"/>	CUSTOM2	<input type="checkbox"/> <input type="checkbox"/>
7.00 inch (178 mm)	<input type="checkbox"/>	<input checked="" type="checkbox"/>	<input type="checkbox"/>	<input checked="" type="checkbox"/>		
8.00 inch (203 mm)	<input type="checkbox"/>	<input type="checkbox"/>	<input checked="" type="checkbox"/>	<input checked="" type="checkbox"/>		
8.25 inch (210 mm)	<input type="checkbox"/>	<input checked="" type="checkbox"/>	<input type="checkbox"/>	<input type="checkbox"/>		
8.50 inch (216 mm)	<input type="checkbox"/>	<input type="checkbox"/>	<input type="checkbox"/>	<input type="checkbox"/>		
10.0 inch (254 mm)	<input type="checkbox"/>	<input type="checkbox"/>	<input type="checkbox"/>	<input checked="" type="checkbox"/>		
11.0 inch (279 mm)	<input type="checkbox"/>	<input type="checkbox"/>	<input checked="" type="checkbox"/>	<input type="checkbox"/>		
12.0 inch (305 mm)	<input checked="" type="checkbox"/>	<input checked="" type="checkbox"/>	<input type="checkbox"/>	<input type="checkbox"/>		

NOTE: The table shows the Kodak standard. If required, a different allocation of the switches to paper widths and surfaces can be defined. Each switch combination can only be used once. (See *Paper Configurations* on Page 4-44.)

When the magazine is in place, the system recognizes the paper width and the paper surface, and offers the corresponding sizes in the print menus for selection.

Defining Cut Lengths

1. Touch:
 - **Settings**
 - **Machine settings**
 - **Cut length**

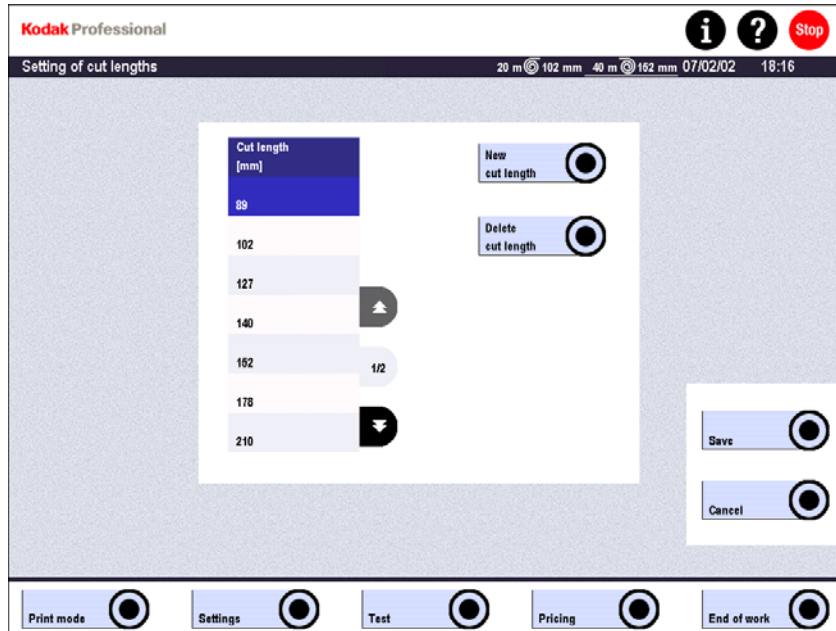

2. Select **New cut length** / **Delete cut length** to update the list of created cut lengths. The range is 82 to 305 mm.

3. Select **Save**.

The cut lengths defined here are offered in the selection boxes of the order configurations.

User Interface

1. Touch:
 - **Settings**
 - **Machine settings**
 - **User interface**

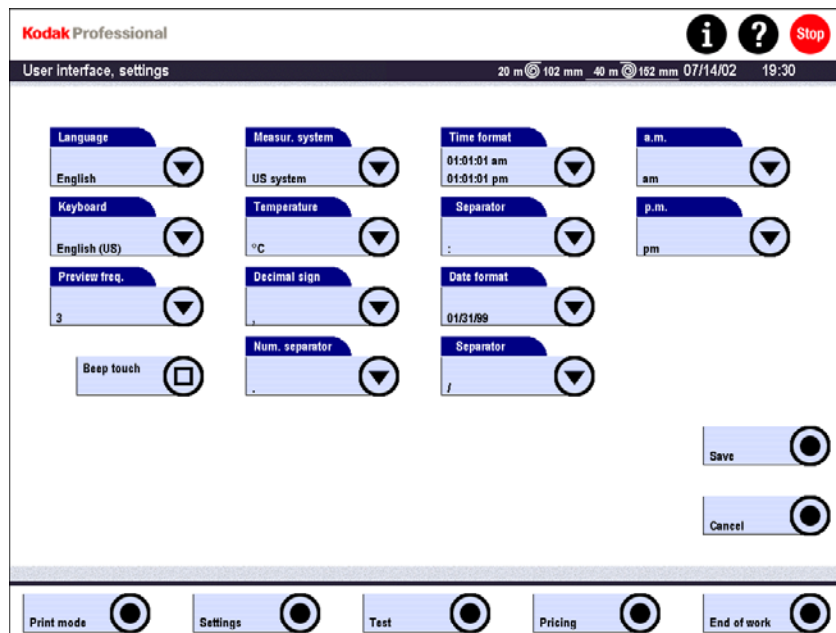

2. Select the data for the user-specific settings:
 - **Language**
German, English, French, Italian, Spanish, Japanese, etc.
 - **Keyboard** for the input screen on the touch screen
 - **Beep Touch** on/off
Acoustic signal after a button has been touched
 - **Preview freq.**
Movement frequency of the images in preview. The fastest possible frequency is preset (3 seconds).
 - **Measuring system, Temperature, Decimal sign and Separator, Time and Date format**
After selection of the language, the national standards are preset automatically. Changes are possible.
Date and time appear in the indicated format in the timer settings and in the backprint.
 - **a.m. / p.m.**
If a 24-hour format is selected for the time display, the buttons for the entry and selection of shortcuts for **morning** and **afternoon** (a.m. / p.m.) cannot be used.
 - **Save**
Modifications become effective only after they have been saved.

User Administrator: Defining Users and User Rights

Enter the settings under **User interface** first, because they are needed for the user-specific settings. Any number of users can be defined, but the following two are required:

- Administrator with user rights for all functions, except service
- Service with unlimited rights for all functions, including service

1. Touch:

- **Settings**
- **Machine settings**
- **User manager**

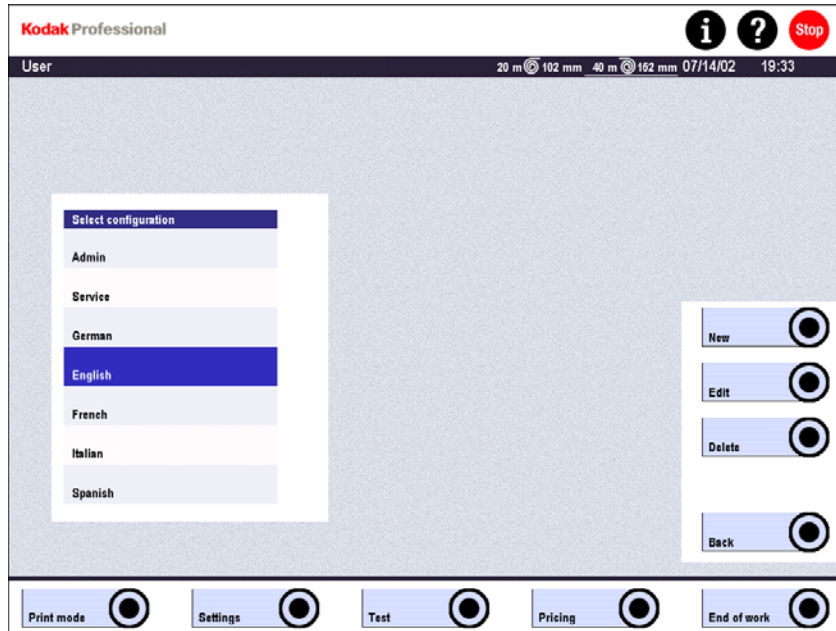

2. Touch **New**.

The next screen opens.

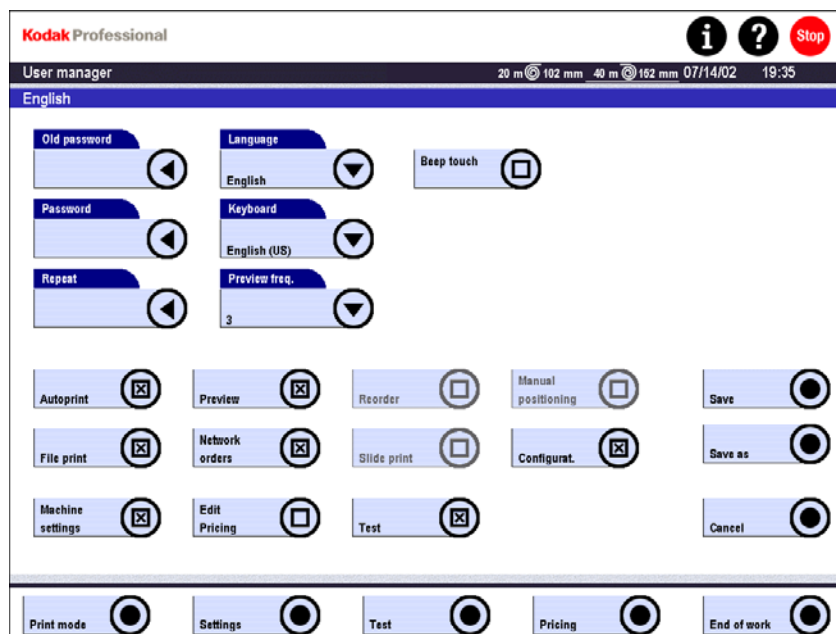

– **Edit**

Select the user in the list and touch **Edit** to change the corresponding settings. The next screen opens.

– **Password, Repeat**

The password (maximum four digits) is defined for new users by double entry. An **Old password** of an existing user can be changed in the same way.

– **Language, Keyboard, Preview frequency, Beep touch**

The entries made in the **User interface** are displayed (see the previous page). These general settings can be adjusted for each individual user.

NOTE: The passwords entered for the system cannot be read or reset anywhere outside this menu. If you forget your password, the corresponding settings cannot be changed.

- User rights

The administrator can combine the user rights listed in the following table individually for each user in order to create a user profile.

Rights	Button	Description
Print modes	File print	Image files of an order (loaded from data carriers)
	Preview	File print with preview
	Network orders	Network orders from a Workstation
Settings	Configurations	Create / modify order configurations including sub-configurations
	Machine settings	Change the settings
Test	Test	MBL, PBL, Remote

- Save

Only shown when the screen is opened using **Edit**

- Save as

User name: maximum 20 characters, special characters not allowed:

„ / \ [] : ; | = + * ? < >

NOTE: Modifications become effective only after the next user login.

Startup: Defining the Start Time / Standard User (Timer)

1. Touch:
 - **Settings**
 - **Machine settings**
 - **Startup**



2. Define:
 - **Automatic Start**
When you enter the start times, allow approximately one hour to preheat the solutions and dryer to the correct operating temperature. Set **Off** for off days.
 - **Sleep mode / Shutdown**
In sleep mode, the system is shut down with the **Shutdown** option in the **End of work** menu. The main computer remains on for checking statistics. It is then switched off automatically at the indicated time. Entering this switch-off time activates the Sleep mode.
 - **Standard Login**
Select a user in the user list to be logged in at the beginning of work.
 - **Automatic Login**
Specify whether the user should be logged in automatically after switch-on, or whether he must identify himself by a password.
 - **No operator actions**
Shutdown when no operator action
If no entry is made for x hours (3 hours is the default setting) directly after the start, the machine switches off automatically.
 - **Edit calendar**
See *Calendar: Defining Off Days* on the next page.
3. Touch **Save**.

Calendar: Defining Off Days

1. Touch:
 - **Settings**
 - **Machine settings**
 - **Startup**
 - **Edit calendar**

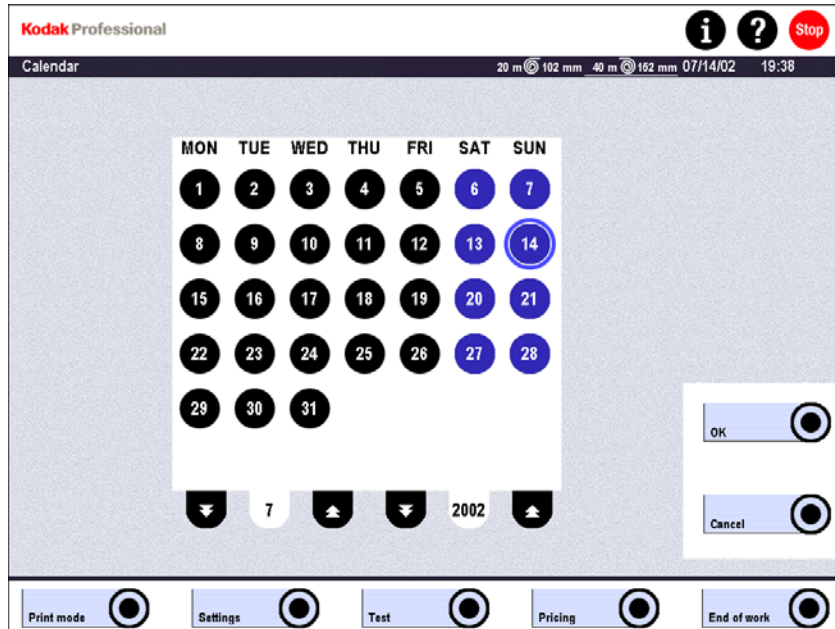

2. Select year / month with the arrow keys.
3. Define off days; for example, company holidays
 - Black for workdays
 - Blue for off days
4. Touch **OK**.

Installing the Software

1. Touch:
 - **Settings**
 - **Machine settings**
 - **Install software**

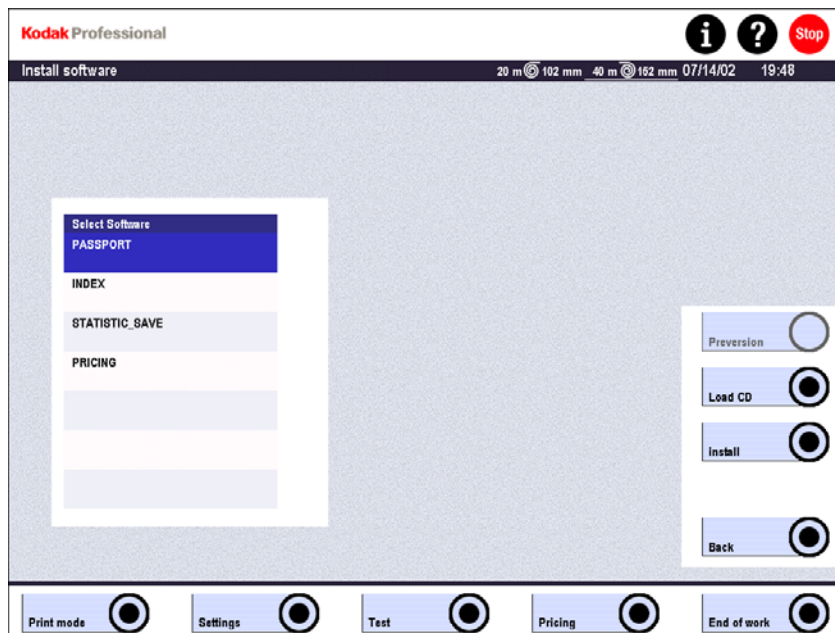

2. Touch **Load CD**.
3. Touch **Install**.
Check if the settings were saved on an external data carrier.
If **No**, the operation is stopped.
If **Yes**, the input screen opens. Enter the serial number.
The software is installed and enabled. Then a new start is enforced.
4. Update the system software.
If the system does not function correctly afterwards, restore the status before the update with the previous version.

Printer Settings

1. Touch:
 - **Settings**
 - **Machine settings**
 - **Printer**

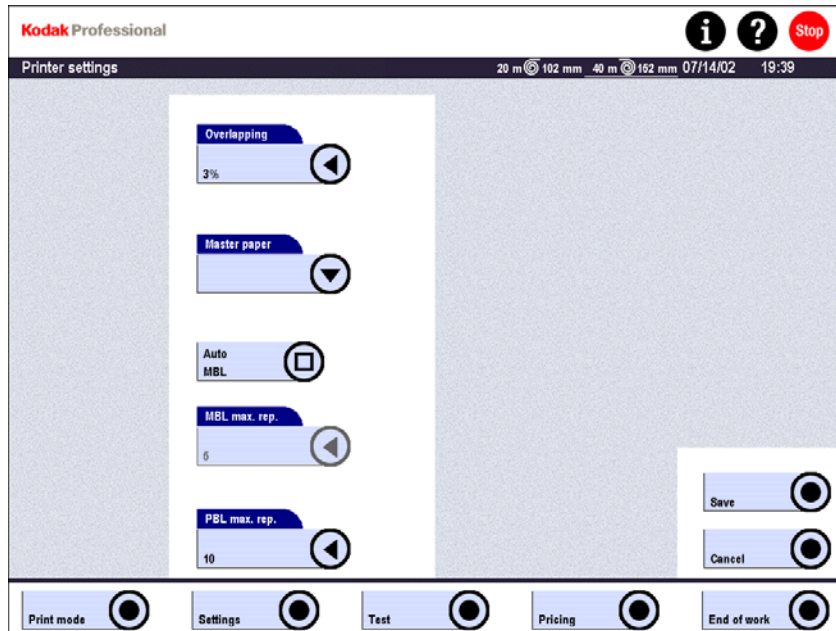

2. Enter the required information:
 - **Overlapping**
Indicate by how many percent the digitized image is calculated greater than the paper to be exposed. The range is 0 to 10%.
 - **Master Paper**
Define the paper used most frequently as master paper. The MBL is performed on this paper.
 - Activate / deactivate **Auto-MBL**
 - **MBL maximum repetitions**
If **Auto-MBL** has been activated, enter how often the MBL test should be repeated automatically if the result is not within tolerance. The range is 1 to 10.
 - **PBL maximum repetitions**
Enter how often the PBL test should be repeated automatically if the result is not within tolerance. The range is 1 to 10.

Paper Processor Settings

Setting the Replenishment Rates

NOTE: It is not possible to modify the individual replenishment rates. The rates for Color Developer, Bleach-Fix, and Stabilizer can only be increased or reduced together at the same ratio. If one of the replenishment rates is changed, the values of the other two solutions are changed in proportion.

CAUTION: If possible, do not change the preset (default) values. Modified values should be reset to standard, if required.

1. Touch:
 - Settings
 - Machine settings
 - PP replenishment

Chemicals	Normal replenishm.		Increased replenishm.		Maximum replenishm.	
	Chemicals [ml/m ²]	Water [ml/m ²]	Chemicals Factor	Water [ml/m ²]	Chemicals Factor	Water [ml/m ²]
DEV	90	0	1.4	60	1.6	80
BX	120	0	1.4	48	1.6	72
STB	240	0	1.4	0	1.6	0

Increased repl. at < (m ²)	10.0	OK
Max. repl. at < (m ²)	5.0	Reset to default
Normal repl. at (m ²)	20.0	Cancel
Average throughput in 5 days	0.0 m ²	Activate normal repl.

2. Enter the required information:
 - The replenishment rates (chemicals / water) for the normal replenishment are indicated in the top part of the screen. More chemicals / water is replenished to keep up the production stability in case of below average throughput. This means that the normal replenishment rates are increased by the entered factor for the increased or the maximum replenishment.
 - The replenishment rates to be used depend on the production. The software calculates daily the average throughput of the last 5 days and sets the appropriate replenishment automatically. Increased replenishment is activated for a throughput of less than 10 m², and the maximum replenishment is activated for a throughput of less than 5 m².

- At the first system startup or after the RP 30 Laser Printer has not been used for some days, you must enter an initial value. Touch **Activate normal repl.** After 5 operating days, the replenishment will be in accordance with the throughput.

Replenishment Rates

Solution	Time in seconds	Replenishment rates
Developer	33	60 ml/m ²
Bleach-fix	33	100 ml/m ²
Stabilizer	69	60 ml/m ² + 140 ml/m ² water

Production Balance – Digital

1. Touch:
 - **Settings**
 - **Machine settings**
 - **Productions Balance**
 - **Digital**

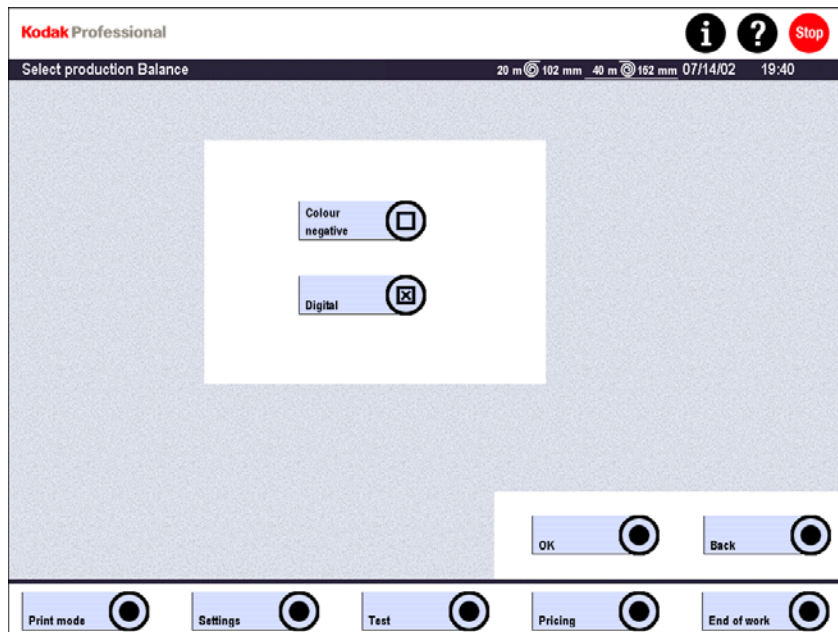

2. Enter the required information for general machine settings, such as detail contrast, sharpness – edges, and saturation.

NOTE: Changes in the production balance should only be made if after a longer observation period and sufficient production experience it is clear that the complete production must be corrected in one direction.

Changes in the parameters shifts the printed results into one direction. For this reason, only experienced operators should modify parameters.

- The settings influence all orders.
- Modifications are only effective after a new start.
- These settings are not considered in the backprint as the production balance defines the basic balance (0-value). Correction values entered later (for example, by way of correction configurations or for image improvement) are added to this 0-value (up to ± 9 maximum) and can be included in the backprint. For color and density corrections, the weighing depends on the entered correction impact (see Impact).

IMPORTANT: *Always leave all parameters in the production balance on 0. Define necessary corrections only by way of the correction configurations, which also lets you select the set values for the backprint.*

Impact

Changes in the correction effect (only influences the color and density regulators):

- Presetting: 100%
- Range: 10 to 200%

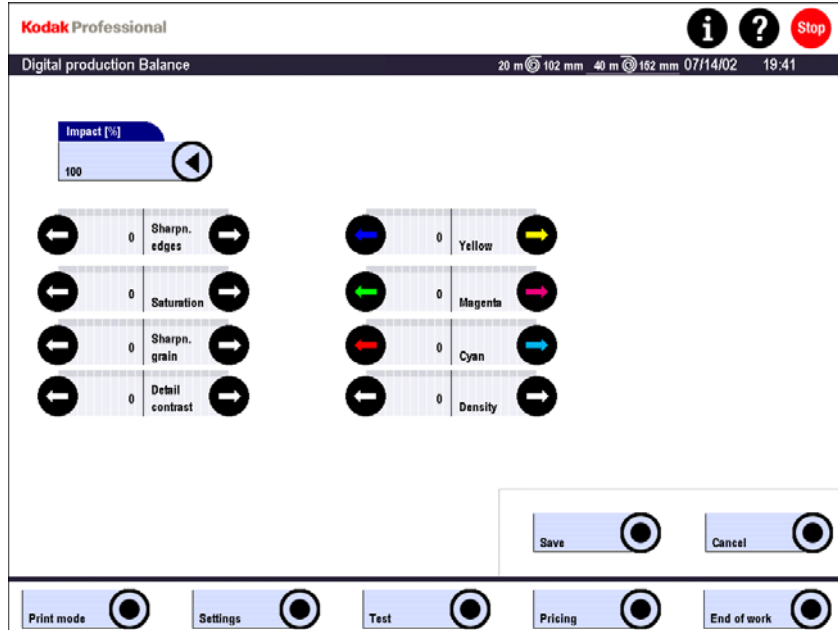

The presetting of 100 should result in a correction density step of about 0.01D and a color step of about 0.03D to 0.04D on the paper (always depending on the paper gradation). The parameter changes are linear; a value of 50 halves the effect and a value of 200 doubles the effect.

Basic setting of the system to modify the colors/density for the whole production: It is effective for all color/density corrections, i.e. in all screens with regulators for yellow, magenta, cyan and density. These corrections do not show in the backprint.

IMPORTANT: *The correction effect should only be changed once in order to adjust the fine grading or the extent of the correction to personal requirements.*

Seasonal changes (color dominant greens and whites) should be compensated only by the corrections themselves, not by the correction effect.

Shifting all 3 colors by the same extent and in the same direction has no effect.

Sharpness of Edges

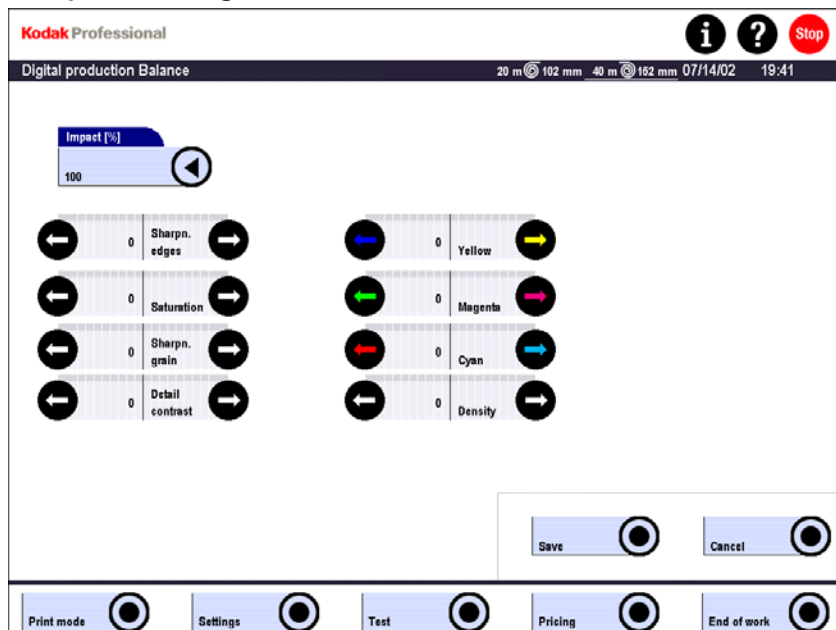

This parameter is used for the correction of light/dark transition along edges, such as a window in a building.

- **Shifting towards +**
The light/dark transition is emphasized, the edge appears sharper.
- Shifting towards –
The edge appears softer.

The impression of sharpness depends on the print size and the paper surface; a special correction configuration should be set up for each print format and surface.

- **Sharpening:**
Only effective if there is sufficient contrast. If it is increased too far the result may be artifacts; for example, thin white lines on dark branches appear artificial ("digital").
Blurred and unsharp exposures are not improved.
- **Soft-focus effect:**
For portrait pictures it may be beneficial to set up a correction configuration with reduced sharpness (–2 to –4), for example to improve skin blemishes.

Saturation

This regulator is used for color prints to change the color saturation. A slight increase in the color saturation may be an advantage for some prints, such as for pictures with many colored areas. However, for faces an increase would exaggerate the saturation. For a normal mixed production a value of 0 is the best setting.

Sharpness of Grain

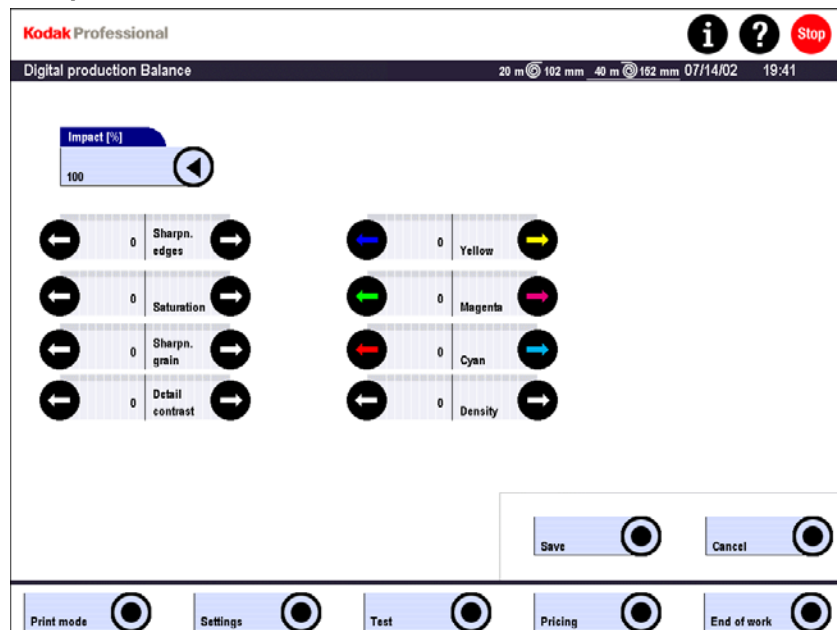

This parameter has a similar effect as **Sharpness of edges**, however on smaller structures (< 1 mm), such as on hair in portraits or on grass.

- **Shifting towards +**
Fine structures appear sharper.
- Shifting towards –
Fine structures appear softer.
- **Fine structuring:**
If the value is increased, fine details become even sharper (such as highlights in the night), but homogenous areas show noise effects.
- **Unsharpness:**
When this value is reduced, the noise is reduced and the grain structure disappears, but details are less sharp and highlights are eliminated.
Grain reduction only with values < 0, for example, –4

Detail Contrast

This parameter influences the sharpness in medium structures (mm to cm), such as faces.

- **Shifting towards +**
Structures appear sharper.
- **Shifting towards –**
Structures appear softer.

Corrections YMCD

- Color / density corrections
- Value range -9 to +9

The effect of the correction input depends on the setup of the **Impact** parameter.

Digital Order Settings

1. Touch:
 - Settings
 - Machine settings
 - Network orders

The screenshot shows the 'Remote Orders settings' interface. At the top, it says 'Kodak Professional' and 'Remote Orders settings'. The interface is split into four quadrants:

- Remote order: File print:** Computer name (10.6.241.232), Resource name (testi).
- Remote order: Autosave:** Computer name (diab_ml), Resource name (bilder).
- Network Orders:** Autom. printing (On / Off), Popup to start network orders appears after ... (5 min), Popup stays active for ... (1 min).
- PDM:** PDM address or name (10.6.241.232), PDM Port no. (pdfcom).

At the bottom, there are buttons for 'Save', 'Cancel', 'Print mode', 'Settings', 'Test', 'Pricing', and 'End of work'.

2. Enter the required information.

Remote Order File Print

Defines an external storage location within the network where image files for the **File print / Remote order** print mode are stored and can be accessed by the RP 30 Laser Printer.



(Access by way of).

When **File print / Remote orders** is started, the system automatically connects to the specified computer / drive.

- **Computer name:** Enter the name or the IP address of a workstation in the network.
- **Resource name**
A shared folder on the specific computer.
 - The folder must be shared on the PC where the folder is located. Password protection must not be activated.
 - Enter the enable name as **Resource name** on the RP 30 Laser Printer. The actual name of the folder is not used.

Remote Order Autosave

Defines an external storage location within the network, where to the RP 30 Laser Printer copies and saves the image files if the **Autosave** function is activated.

- **Computer name**
See *Remote Order File Print* above.
- **Resource name**
See *Remote Order File Print* above.

Network Orders

These parameters allow automatic printing of network orders in print breaks (no activity by the operator within a certain adjustable time). The RP 30 Laser Printer automatically switches to the print mode **Network orders** and prints the orders waiting there.

The screenshot shows the 'Remote Orders settings' window. At the top, it displays 'Kodak Professional' and system information: '20 m 102 mm 40 m 152 mm 07/14/02 21:46'. The window is divided into four main sections:

- Remote order: File print:** Contains 'Computer name' (10.6.241.233) and 'Resource name' (testi).
- Remote order: Autosave:** Contains 'Computer name' (dlab_ml) and 'Resource name' (bilder).
- Network Orders:** Contains 'Autom. printing' (On / Off), 'Popup to start network orders appears after ...' (5 min), and 'Popup stays active for ...' (1 min).
- PDM:** Contains 'PDM address or name' (10.6.241.232) and 'PDM Port no.' (pfdcom).

At the bottom right of the settings area are 'Save' and 'Cancel' buttons. At the very bottom of the window is a navigation bar with buttons for 'Print mode', 'Settings', 'Test', 'Pricing', and 'End of work'.

- **Automatic printing** On/Off
- Time span without operator action after which the pop-up for digital orders is to be displayed (5 minutes is the default value).
- **Duration of the pop-up display** after which the printing of digital orders is started automatically if no operator action takes place (1 minute is the default value).

PDM (D-Bridge)

Information about the PC (PDM Server) on which the PDM Software is installed (required for network orders):

- **Address or name**
Name or IP address
- **Port no.** (Standard is 5001 or pfdmcom, if the corresponding input in the SERVICES file exists)

PFDF (Photofinishing Data Format) is a standardized format for order data to be used in networks.

The **PDM (PFDF Data Manager)** manages the order files. It saves digital orders (images and PFDF information) until a receiving station such as the RP 30 Laser Printer calls them.

In network connections with several input devices, the D-Bridge should be installed on a PC that is only responsible for this task (prerequisites: 32-Bit WINDOWS PC, WINDOWS 2000 operating system, at least 700 MHz, at least 128 MB RAM, at least 20 GB hard disk).

For information about the current **PDM Software (D-Bridge)**, please contact Kodak.

Other Settings

1. Touch:
 - **Settings**
 - **Machine settings**
 - **Other settings**

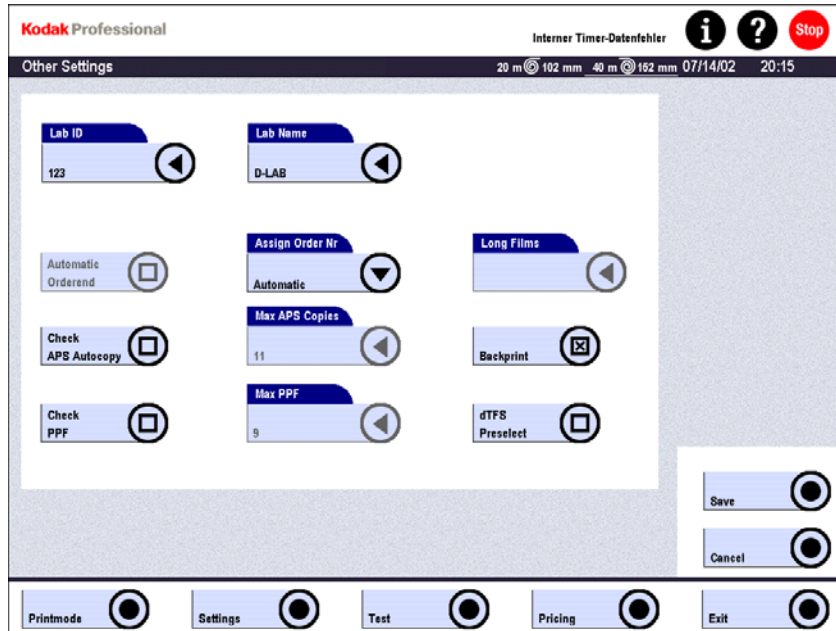

2. Enter the following information required for the production:
 - **Lab ID**
Equipment-specific identification number within a laboratory. Can be included in the backprint.
Permissible range: 160 to 169
 - **Lab name**
Free name. Can be included in the backprint.
 - **Order no.**
 - **Manual**
The order number displayed for the operator can change the printing of an order in File print mode.
 - **Automatic**
The order number in the **File print** mode is assigned by the system and cannot be changed by the operator.

- **Check PpF**

If this parameter is activated a warning message will be displayed as soon as the number of prints (PpF) entered for an order exceeds the value defined in the **Max. PpF** field. Work continues as soon as the warning is confirmed. There is no automatic correction for PpF.
- **Max. PpF**

Maximum number of prints per frame that will be printed without a warning display.
- **Backprint**

Activation of the backprint for the **File print** mode. If this parameter is inactive, no backprint can be selected for the order.
The backprint in the print mode **Network order** is always controlled by the order data created at an external Workstation independent of the status of the **Backprint** parameter in this menu.
- **dTFS Preselection**

Presetting of the use of dTFS in the **File print** mode. If the parameter is activated **dTFS** is available for selection in the order menu, otherwise it is not available.

Print Configurations

1. Touch:
 - Settings
 - Print configurations

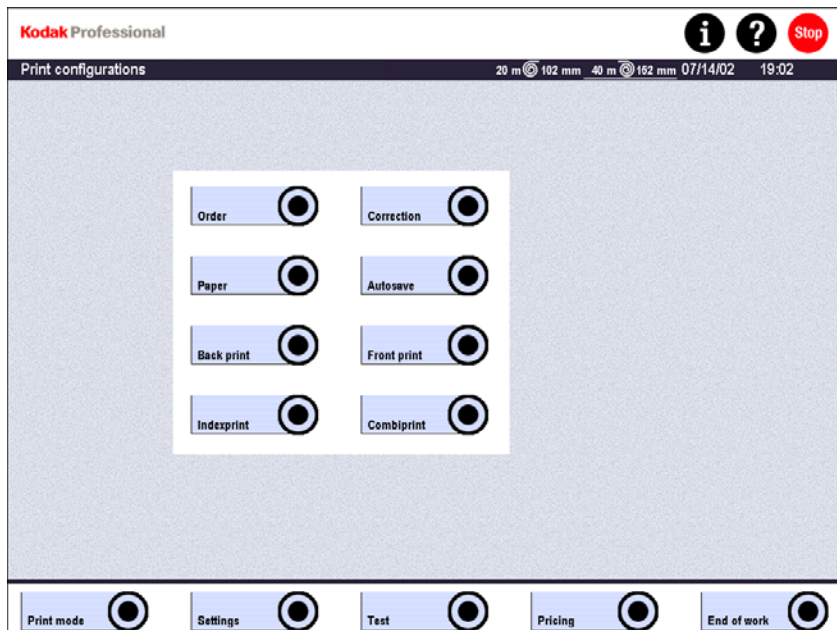
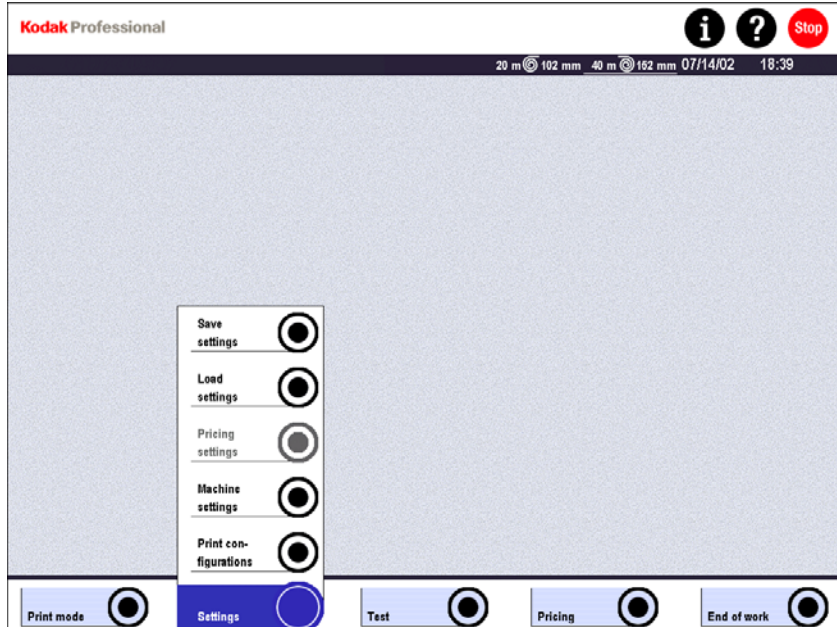

2. Enter the required information.

All the settings required for creating the desired print size (for example, 9 x 13) including further options (such as backprint) are stored in the print configurations.

For this, the following configurations are defined:

- **Paper**
- **Backprint**
- **Correction**
- **AutoSave**
- **Front print**
- **Order**
Single, Package, Reproduction

Order configurations are combined on the basis of the other configuration types. For this reason, these sub-configurations must be created first.

A sub-configuration can be used in any number of order configurations.

Creating, Editing, and Deleting Configurations

The various configuration lists contain all related sub-configurations.

Creating a New Configuration

1. Touch **New**.

A screen appears with the existing preset values.

In some configuration menus the **Film mask** field is displayed. Here the meaning of this term is “image source.”

For the RP 30 Laser Printer, only one image source can be set up, which is **File print**. This parameter has a fixed allocation and cannot be changed.

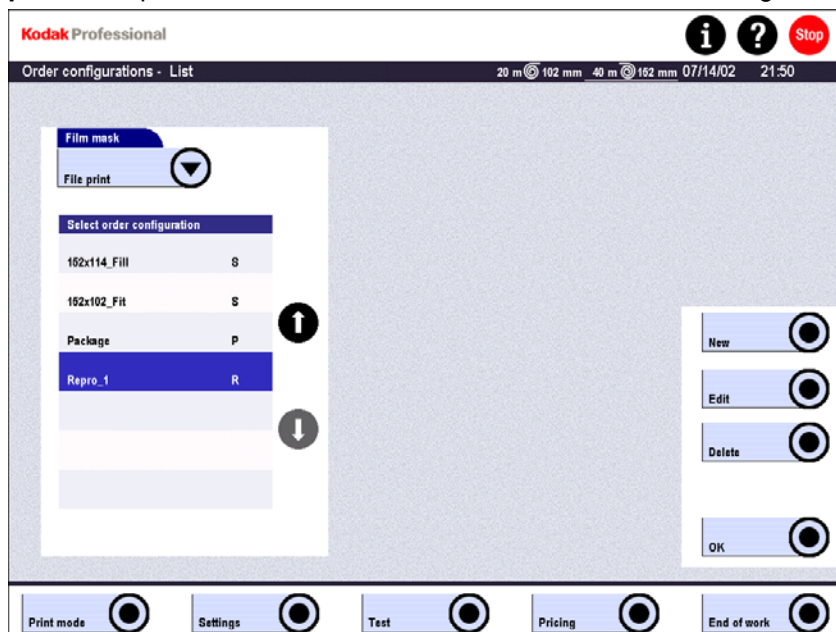

2. Enter the settings.
3. Touch **Save as** and enter a meaningful name in the input screen:
 - Maximum of 30 characters
 - Permissible special characters:
- . : , ; + ! ? = () _ / & % \$ and blanks

Creating a New Configuration Based on an Existing One

1. Touch a similar configuration in the list.
2. Touch **Edit** and enter the settings in the next screen that differ from the basic configuration.
3. Enter **Save as** and a new name.

Editing a Configuration

1. Touch the configuration.
2. Touch **Edit** and modify the settings in the next screen.
3. Save.

Deleting a Configuration

1. Touch the name in the configuration list and touch **Delete**.
2. If the configuration is used in a main configuration, you do not have to delete the main configuration. Instead, select another configuration to replace the deleted one.
 - Sub-configuration used in the order configuration
 - Order configuration Single used in the order configuration Package
3. To exit the screen without modifications, touch **Cancel**.

Paper Configurations

A paper configuration consists of a paper setting for each (width) and a surface. The cut length of the paper is kept independent of the paper configuration, and it can be assigned to an order configuration in the Order menu.

Creating a Paper Configuration

1. Touch:
 - **Settings**
 - **Print configurations**
 - **Paper**
 - **New or Edit**





2. Select from the **Paper Settings** and the **Paper Surfaces**.

The paper settings and surfaces created before in the **Machine settings** are now offered.

- Switches for the paper magazine change
- Switches 1 to 4 define the paper width
- Switches 5 and 6 define the surface
- The switch positions are defined under **Settings / Machine settings / Surfaces and Paper settings**. They cannot be modified here.

IMPORTANT: *Each switch combination of the magazine switches may only be used ONCE.*

3. Touch **Save** or **Save as**.

Backprint Configurations

Settings apply to the print mode **File print**. For Network orders, the backprint is part of the image individual order data. The print field is 2 x 40 characters. Positions not used are filled with points.

1. Touch:
 - **Settings**
 - **Print configurations**
 - **Backprint**
 - **New or Edit**

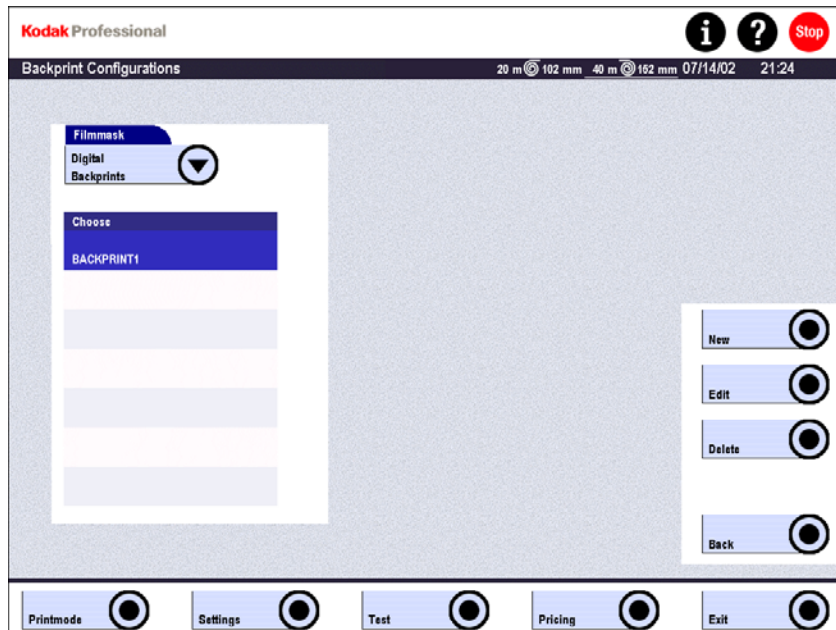

2. Select **File print** from **Filmmask**.

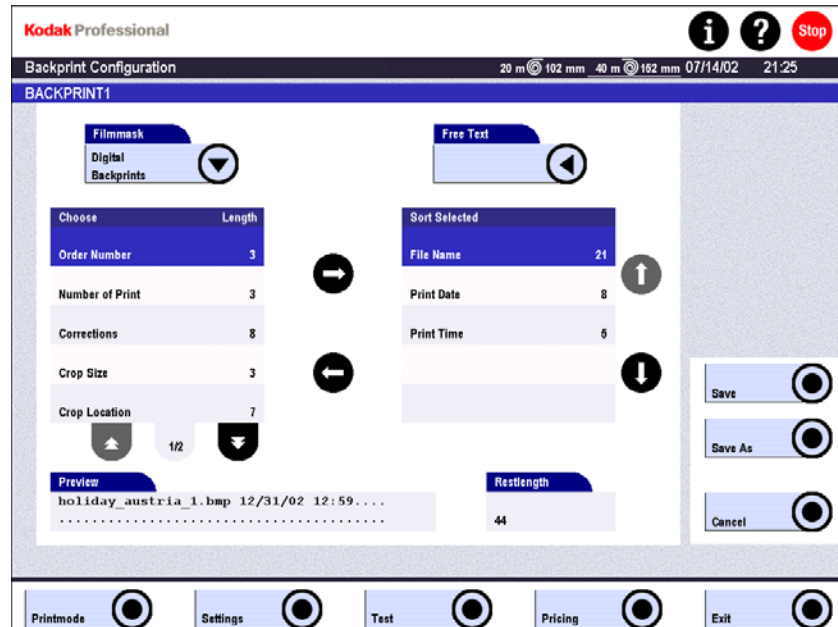

Here the meaning of the term "Film mask" is "image source."

For the RP 30 Laser Printer, the image source **File print** is fixed and cannot be changed.

3. Create backprint text with a combination of the machine-generated parameters and additional operator comments.
 - a. Add → or Remove ← parameters.
 - b. If **Free text** was selected, touch the field of the same name and enter the text.

The preview of the backprint text and the indication about still-available blanks are constantly updated.

4. Sort the selection list with the arrow keys ↑↓. This determines the order in the backprint text.
5. Select **Save** or **Save as**.
If the total length of 80 characters is exceeded, a message is displayed.

Here is some additional information about some of the parameters.

Print date/time is printed for the formats selected under Machine settings / User interface.

Color / density corrections prints the corrections of the correction configuration plus the manual corrections. Because of this data in the backprint, exact reorders are possible. The corrections are entered in the **Production balance** menu. Digital is considered a basic balance for the **File print** mode. Since these corrections have no effect on individual prints of the order, they are not included in the backprint.

Because there are only five positions available in the backprint for corrections, abbreviations are necessary for the values from -9 to +9.

Correction	-9	-8	-7	-6	-5	-4	-3	-2	-1	0	+1	+2	+3	+4	+5	+6	+7	+8	+9
Backprint	I	H	G	F	E	D	C	B	A	N	1	2	3	4	5	6	7	8	9

The corrections are shown in sequence for:

- Color / density corrections
- Sharpness - edges
- Saturation
- Sharpness - grain
- Detail contrast

For example, "C 2 4 N 1" would indicate the following corrections:

- Color/density: -3
- Sharpness - edges: +2
- Saturation: +4
- Sharpness - grain: 0
- Detail contrast: +1

Correction Configurations

The options the RP 30 Laser Printer offers to improve the image can be combined in special configurations, named and saved, for certain subject groups (snow shots) or certain customers.

Correction configurations are only effective in the **File print** mode.

1. Touch:
 - **Settings**
 - **Print configurations**
 - **Corrections**
 - **New or Edit**



2. Enter the Corrections: -9 to +9 for:
 - **Sharpness - edges**
 - **Saturation**
 - **Sharpness - grain**
 - **Detail contrast**
 - **Yellow, Magenta, Cyan, Density** (color / density corrections)

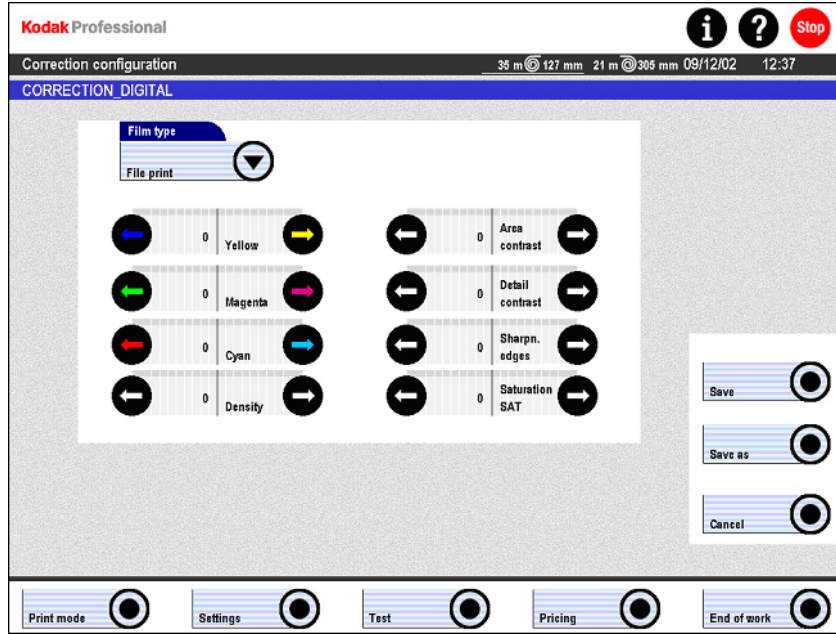

For explanations of the function of these corrections, see *Production Balance – Digital* on Page 4-30. These corrections appear in the backprint if backprint text was selected. See *Backprint Configurations* on Page 4-46.

Autosave Configurations

Autosave configurations are used to save image files on a data carrier. The aspect ratio is kept.

A folder is set up for every order on the data carrier:

- The folder name = order name_date/time (for example: 001_0208051130).
- The files copied into this folder are named as follows:
File name_internal image number.format (for example: Testprint_0001.bmp)

1. Touch:

- **Settings**
- **Print configurations**
- **Autosave**
- **New or Edit**

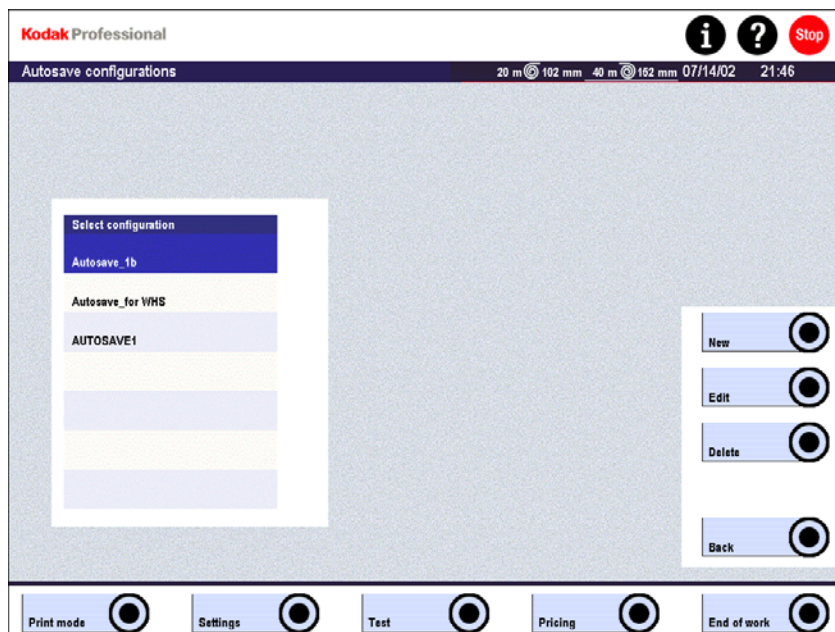

2. Select the type of Autosave configuration.

The three types exclude each other. As a result, only the selection box belonging to the selected type is active.

Autosave fixed

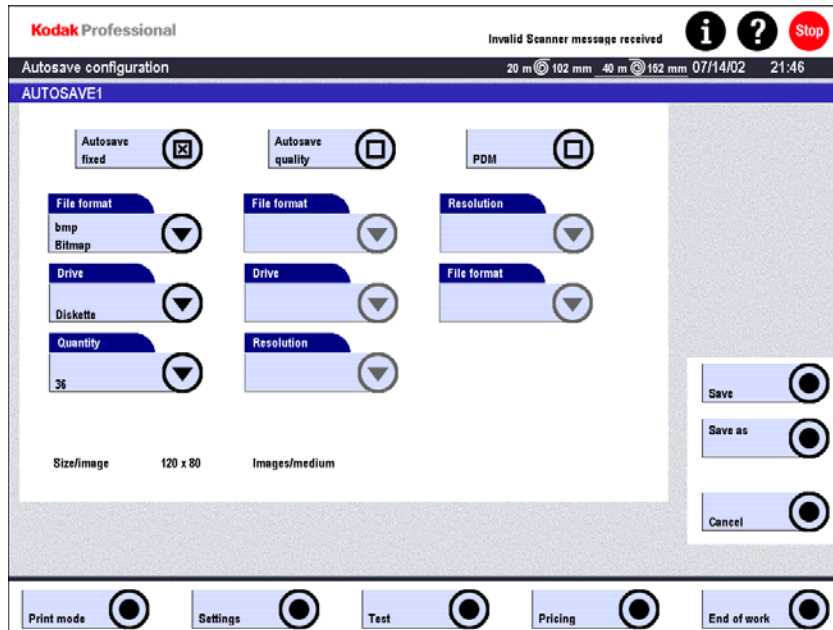

- **File format**

In this mode, the files are always saved in the format bmp.

- **Drive**

Selection of a local drive: floppy disk.

- **Quantity**

Enter the number of image files that are to be saved on the selected medium. As the storage capacity of the selected medium cannot be changed, the resolution of the image is automatically adapted to fit the desired number on the medium.

High number = low resolution

Low number = high resolution

Autosave quality

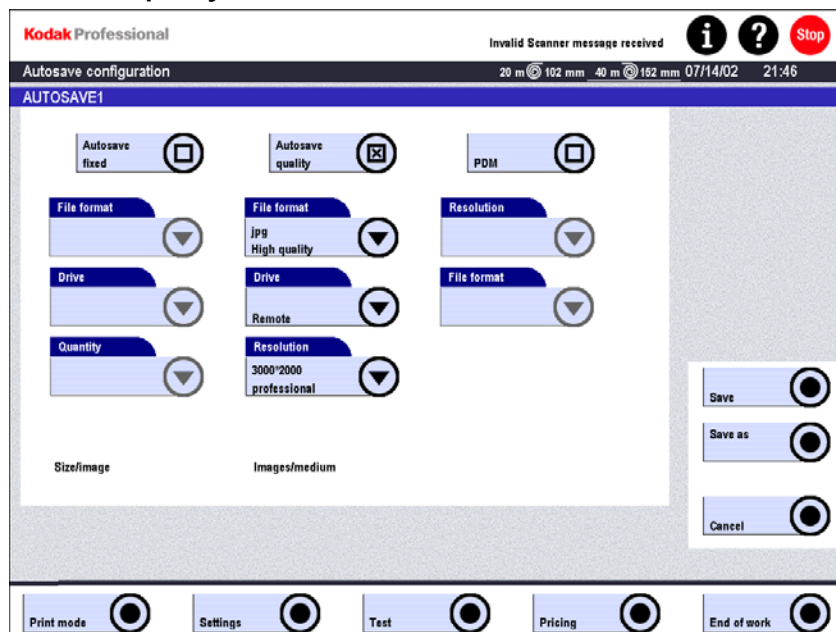

- **File format**
bmp or jpg with various compression factors.
- **Drive**
Selection of a local drive (floppy) or external drive. The folder defined and shared in the menu **Settings / Machine settings / Network orders / Remote orders: Autosave** is offered.
- **Resolution**
Four different resolutions are offered.

PDM (D-Bridge)

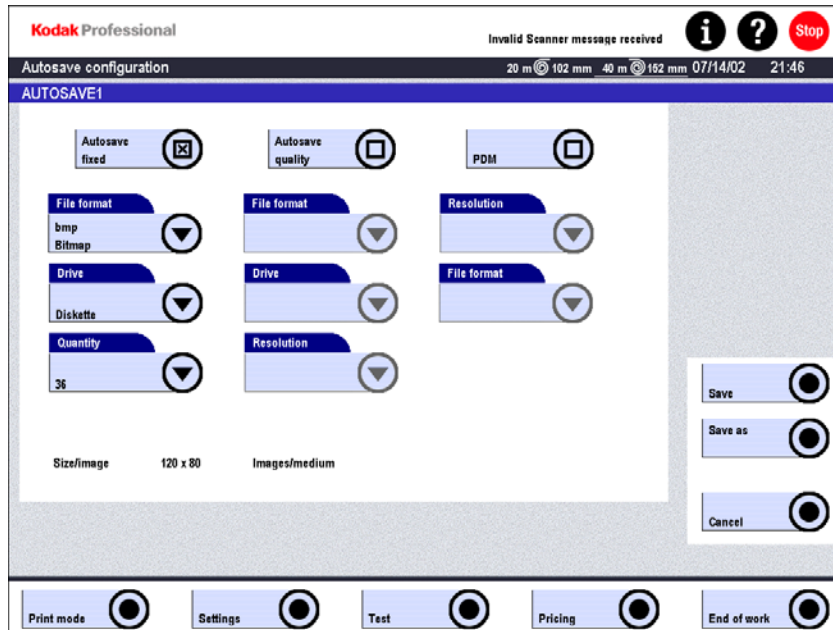

- **Resolution and File format as in Autosave quality.**
The address of the PC where the PDM server (D-Bridge) is installed has been defined before. See *Network Orders* on Page 4-36.
 - **CD, Internet Upload, Normal**
If one or more of these fields is selected, the stored image files in the corresponding order file are marked. This marking allows an automatic further processing of the files by way of the programs connected with the PDM, such as writing to a CD.
3. Select **Save** or **Save as**.

Front Print Configurations

Front print configurations let you expose free text on the front of the print.

1. Touch:
 - **Settings**
 - **Print configurations**
 - **Front print**
 - **New or Edit**

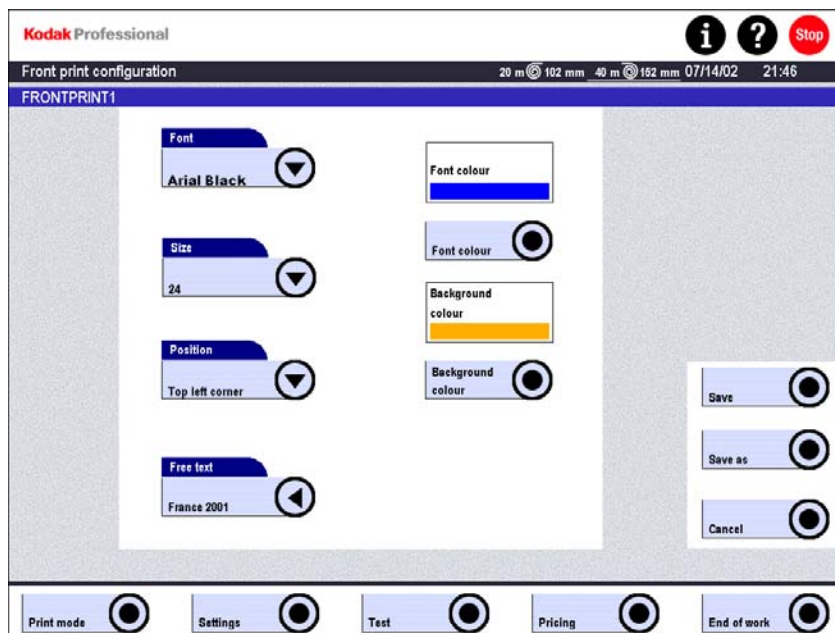

2. Select **Font**, **Size** and **Position**.
3. Touch **Font color** or **Background color**.

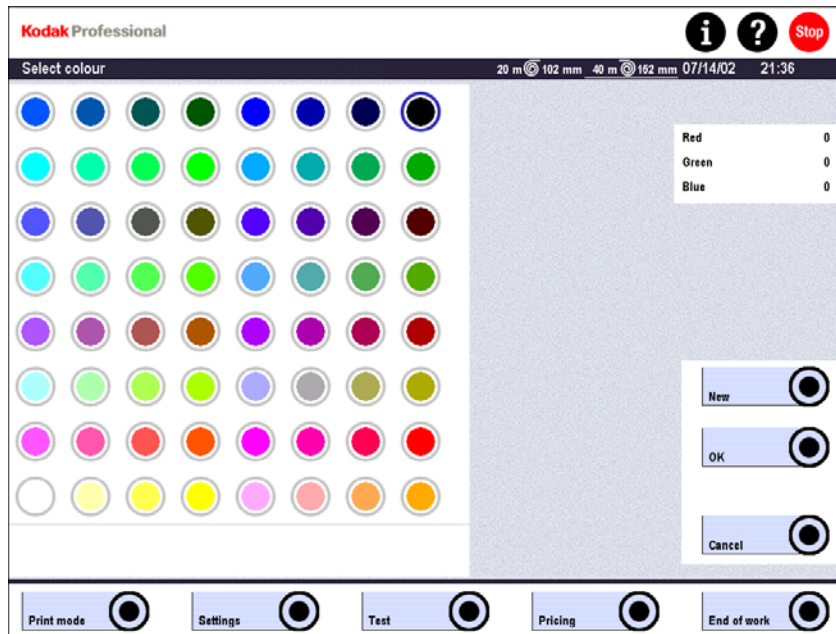

4. Select the color and press **OK**
or
Select the color and press **New**.
Modify the red, green, blue color parts in the next screen to create the desired color and press **OK** twice.
5. Select **Save** or **Save as**.

Order Configurations

As the sub-configurations are accessed in the order configurations, they must always be created first.

A created sub-configuration can be used in any number of order configurations.

1. Touch:
 - **Settings**
 - **Print configurations**
 - **Order**
 - **New or Edit**

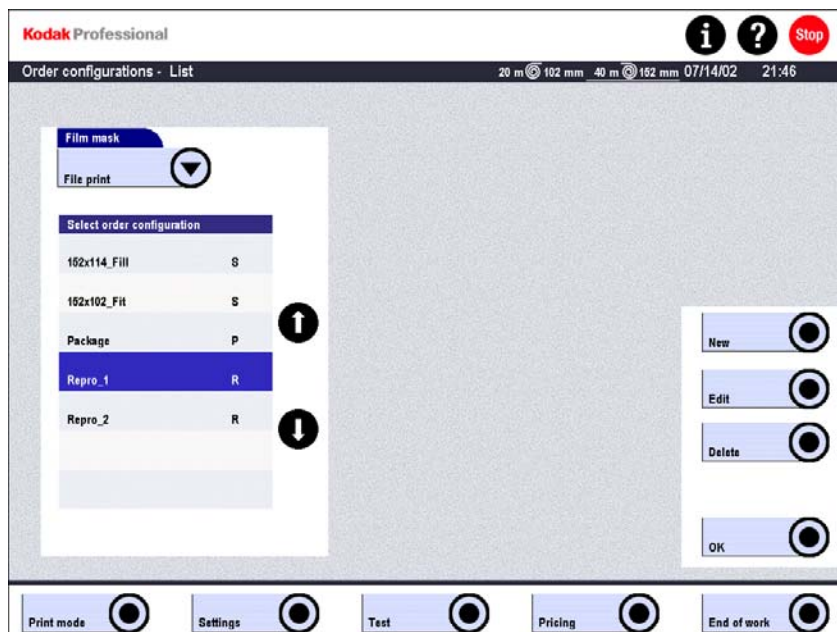

2. Select **Film mask**.

The software is used for configuration with and without a scanner. The term "Film mask" in the RP 30 Laser Printer stands for "Filter". The associated configurations, previously created, are listed.

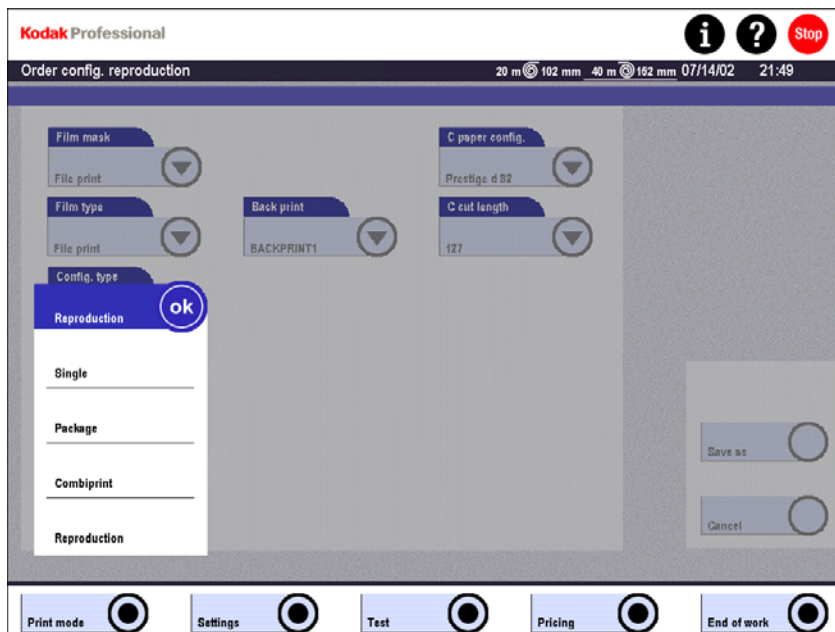

3. Select the Configuration type.

- **Single**

A single order configuration. See *Creating a Single Configuration* on the next page.

- **Package**

Several single order configurations are combined in one package to print different sizes from one Image file in one step. This means that single order configurations must be created before a package can be created. See *Creating a Package Configuration* on Page 4-60.

- **Reproduction**

This order configuration switches off all functions of the image enhancement so that the prints correspond exactly to the original. This also refers to the computing of the print size. The printed image corresponds precisely to the original. For deviating sizes, there is a border or loss of image information. Application example: Prints created with programs such as *Photoshop* or shots artificially falsified.

Creating a Single Configuration

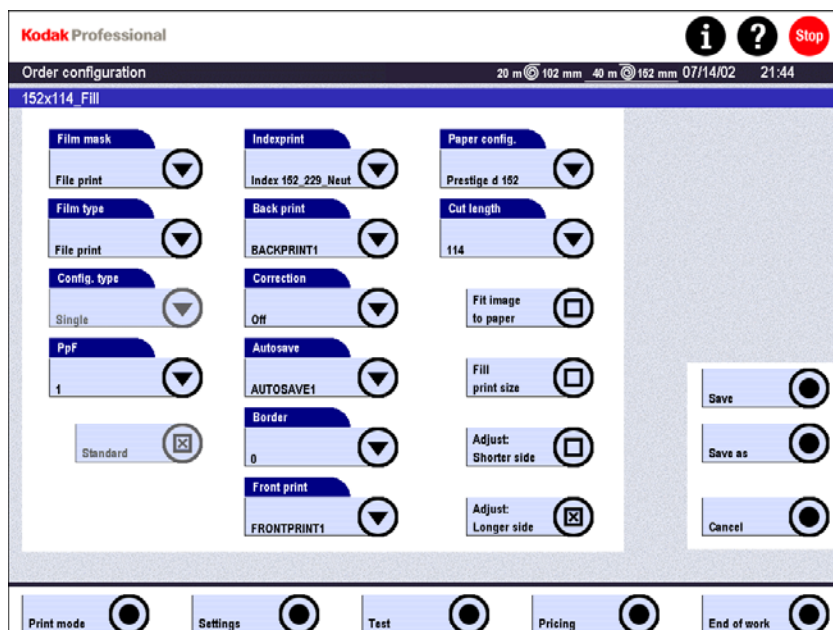

1. Set the Configuration type to **Single**.
2. Select **Film mask: File print**.
3. Select sub-configurations or set to **OFF**.
4. Select **PpF** (number of prints per frame). The default value is 1.
5. Enter the **Border** size, from 4 to 60 mm, or 0 for borderless.
6. Specify **Paper configuration** and **Cut length**.
7. Select a crop:
 - a. **Fit image to paper** (standard): The image remains unchanged and the border is added.
 - b. **Fill print size**: Center cropping; some image information is lost.
 - c. **Adjust: shorter side / longer side**: The image is kept; the cut length is variable. One side of the digital image is adjusted to the paper width, either the shorter side or the longer side.
8. Select **Save** or **Save as**.

Creating a Package Configuration

You can use any combination of order configurations. If a configuration with more than two paper widths is used for printing, you may be asked to change the paper magazine.

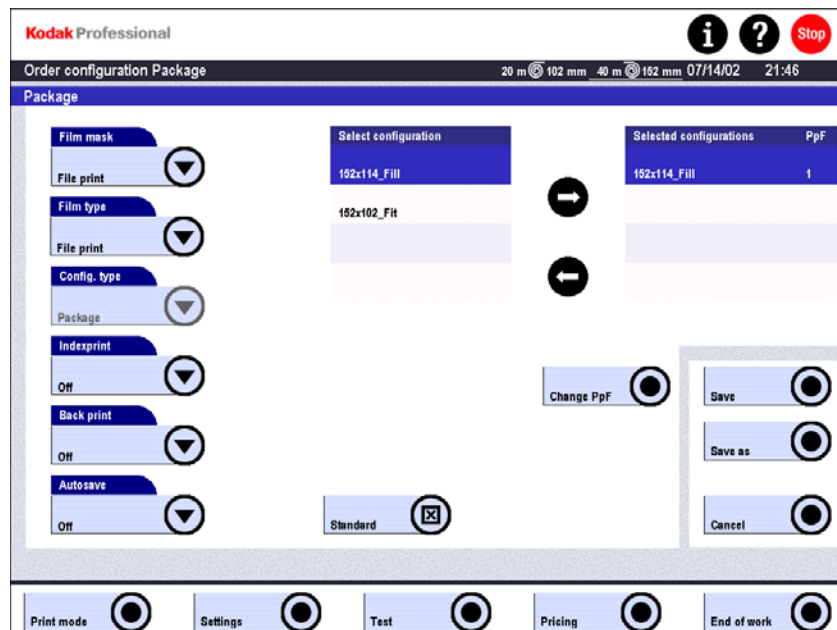

1. Select **Film mask** and **Film type**.
In the RP 30 Laser Printer, both terms correspond to the term **Image source**.
2. Set the **Configuration type** to **Package**.
3. Select sub-configurations or set to **OFF**.
4. Select **Change PpF** (number of prints per frame). The default value is 1.
5. Select either **Off** or **On** for **Index**, **Backprint**, and **Autosave**.
The settings made here are applied. The settings in the single configurations on which they are based are ignored.
6. Select **Configurations**.
Only order configurations are offered that match the selected image source (film mask) and are not packages themselves (the latter cannot be packed any further) and in which **PpF** is not zero.
Add configurations to the selection list with **→**, or with **←**.
7. Select **Save** or **Save as**.

For the **Standard** button, see *Defining a Configuration as the Standard Configuration* on Page 4-63.

Reproduction

Order configuration for image files that are to be printed without automatic image improvement.

Printing is without preview. The configuration cannot be changed. The image is printed in the middle of a large size (400 dpi), e.g. for CD Inlays.

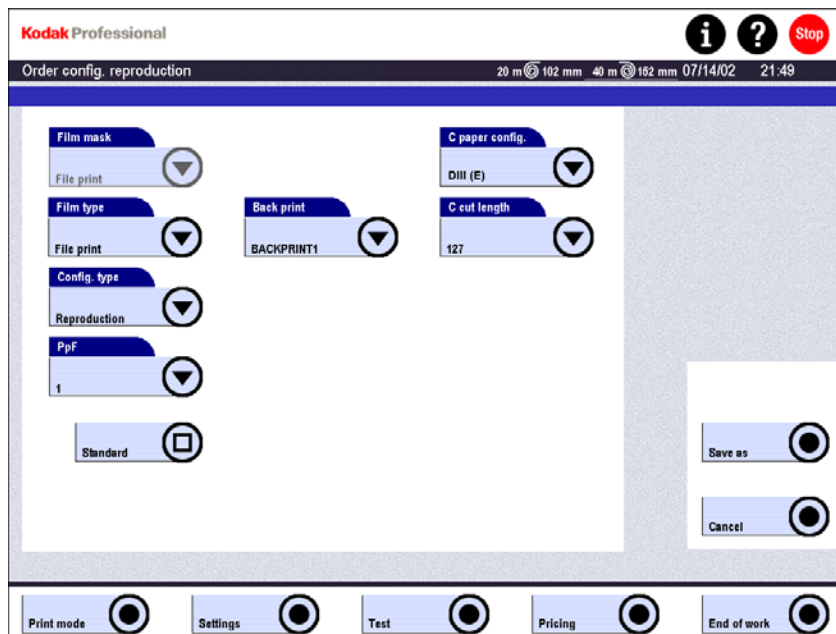

1. Set **Film mask** and **Film type** on **File print**.
2. Set **Configuration type** to **Reproduction**.
3. Select **Backprint** or set to **OFF**.
4. Select **PpF** (number of prints per frame). The default value is 1.
5. Specify **Paper configuration** and **Cut length**.
6. Select **Save** or **Save as**.

Configuration Types in the Order Configuration List

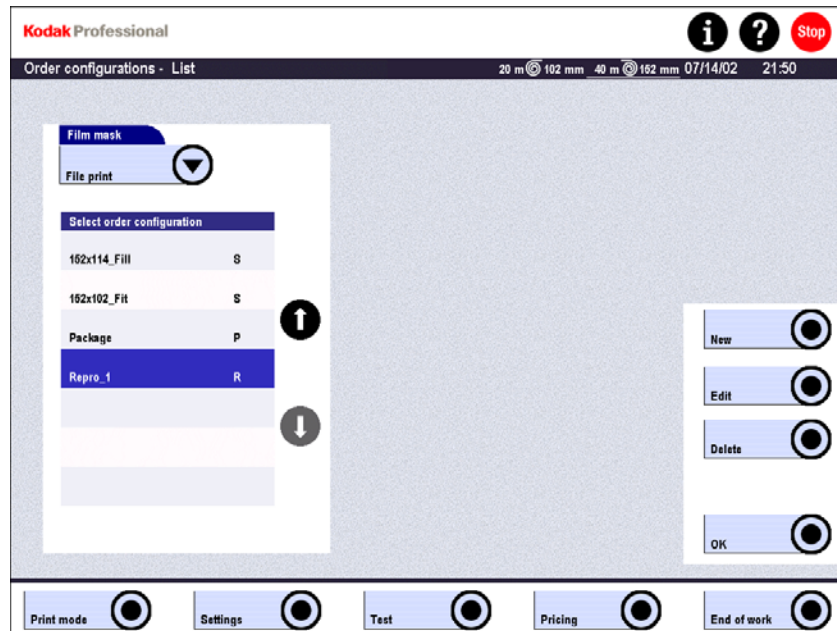

The configuration types are identified in the list by letters:

- S** Single
- P** Package
- R** Reproduction

The standard configuration is always shown in the first line in all configuration lists.

Black-and-White and Sepia Prints

Automatic conversion of color information in the original to black-and-white or sepia is not possible.

The original file must be converted outside the RP 30 Laser Printer, using Photoshop or a comparable program.

Defining a Configuration as the Standard Configuration

One of the previously created Single and Package order configurations can be defined as the Standard configuration. This standard configuration is shown at the top of the configuration list and is used automatically:

- After the start
- After changing the print mode

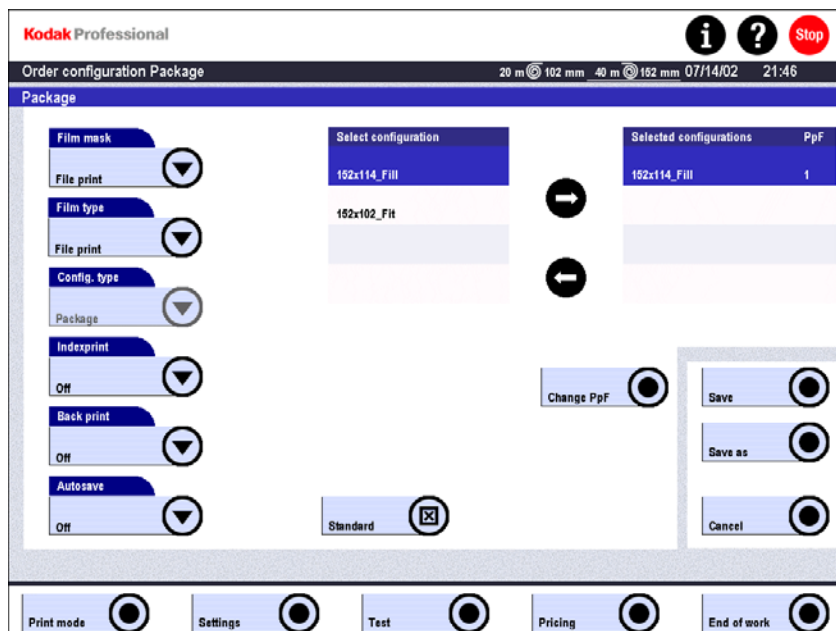

Activate **Standard** in the desired configuration (near the bottom of the screen).

Saving and Loading Settings and Configurations

When to Save Settings

- After the first machine startup and the creation of customer configurations.
- After major modifications of settings and/or configurations.
- At regular intervals, such as after a PBL.
- Prior to the installation of a software update. This is recommended because the reloading of the Backup (restore) is only possible with the same software version. Otherwise, the database might be destroyed. If you are not sure of the software version, use **Info** to check.
- When you want to copy configurations to other systems.

Procedure

1. Touch:
 - **Settings**
 - **Save settings**



2. Select the drive (symbol) / directory (arrow). A Zip disk is recommended if many data base entries are modified.
All files of the drive / directory a listed on the left side; on the right side, there are the existing backup files. The file name is an indicator for what is saved.
3. Select **Save** or **Save as**.

Load Settings

1. Touch:
 - Settings
 - Load settings



2. Mark the desired information by checking the box.
3. Select a medium, if necessary, a directory and a file name.
4. Select **Load**.

Chapter 5 Tests

Contents

Introduction.....	5-3
Printer Tests.....	5-3
Overview.....	5-3
MBL	5-3
PBL	5-3
Prerequisites for MBL and PBL Calibration.....	5-4
Printing a PBL Test.....	5-4
PBL Test with Laser Point	5-5
Printing an MBL Test.....	5-6
Procedure for the First Machine Operation or After New Software Installation	5-7
Daily Calibration With the MBL.....	5-8
Daily Calibration Without the MBL.....	5-8
Calibration of New Paper, Emulsion Changes, or Correction of a Paper Channel (Not Master Paper).....	5-9
Calibration of New Paper, Emulsion Changes (Master Paper).....	5-9
Completion of the New Calibration.....	5-9
Testing the Paper Processor.....	5-10

Introduction

Before the start of production, the printer and paper processor must be carefully calibrated to produce only the highest quality prints.

The purpose of the printer calibration is to align the individual elements of the KODAK PROFESSIONAL RP 30 Laser Printer – print engine, paper, and paper processor – with respect to each other. The result of a successful calibration is the neutral appearance of the grayscale on the last test print.

You can perform tests for the RP 30 Laser Printer before or during production. For example, a Paper Balance (**PBL**) test is required when paper with a new emulsion number is inserted.

This chapter provides details about these tests.

Printer Tests

Overview

MBL

The **Master Balance** (MBL) is the means to keep the production stable and uniform. This provides consistent, every day compensation for chemical fluctuations and/or changes in the paper process.

The **MBL** is printed on the “master” paper, which is the paper that is used most frequently in the lab. The MBL then calibrates the master paper directly. Based on the changes determined on the master paper between the last and the current MBL, all other paper styles are adapted. Therefore, any change in the MBL influences all paper configurations.

PBL

The **Paper Balance** (PBL) test compensates for the differences among the various paper types and widths, and provides for uniform rendering of the colors on all paper emulsions in use.

The **PBL** calibration only applies to the paper on which the **PBL** is printed. Other paper styles are not affected. Every paper configuration (for example, every individual cassette code) used for production must be calibrated.

The **PBL** consists of two steps:

1. The working point of the laser and the maximum densities are determined for the paper. Usually this step is only required once, when the **PBL** is determined for the first time. For this purpose, the test print's **graded densities** and **halo print** are exposed.
2. The **PBL** test print is used to adjust a neutral grayscale. Several cycles are usually required.

Prerequisites for MBL and PBL Calibration

Before printing the MBL and PBL calibration:

1. Check that there are no print orders pending.
2. Use the Information (i) button to check that no paper is in the paper transport of the printer and the paper processor for the MBL and the PBL calibration.
3. Check that there is enough paper in the magazine for the two tests (approximately 3 m [40 in.]).
4. Check that the chemical solutions are at nominal temperature.

Printing a PBL Test

When it is necessary to print a PBL test, follow these instructions.

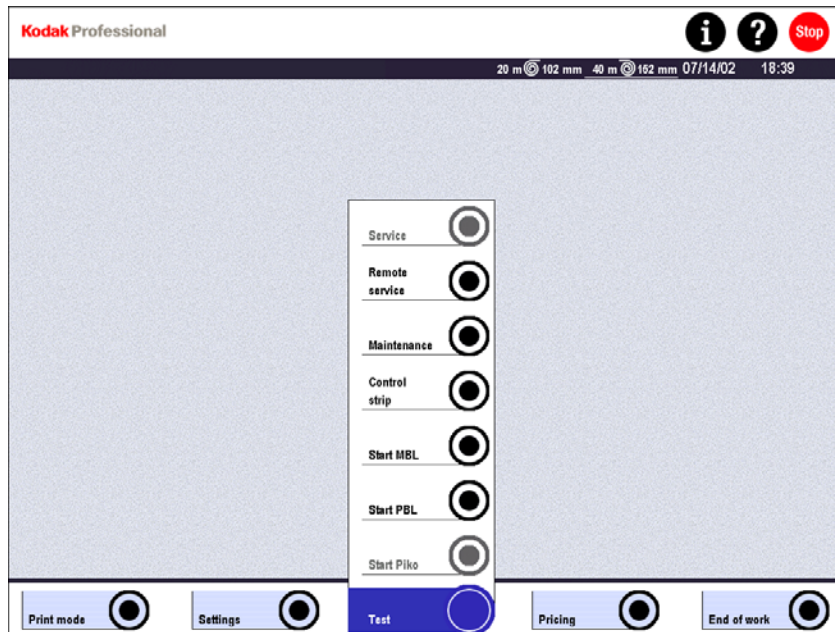

1. Touch:
 - **Test**
 - **Start PBL**
2. Select the paper configuration for which the PBL test is to be printed.
3. Touch **PBL** to print the test.
4. Enter in the next screen:
 - **Emulsion no.** (only for information, not assessed)
 - **Tolerance:** Step width 0.1 mm
Possible input of the manually measured deviation of the paper from the coded width (useful for border prints).
5. Activate / deactivate **with Laser point**.
6. Touch **Start**.

You can use the **Settings** menu (see Chapter 4) to set up how often the automatic PBL should be repeated if the values continue to be out of tolerance after retries. The number of retries can be from 1 to 10.

PBL Test with Laser Point

The laser point is used to set the exposure levels required to produce the desired D-max value of the paper being tested.

NOTE: You can press [Alt] + [F1] to set the D-max for a paper. The PapersData dialog box appears.

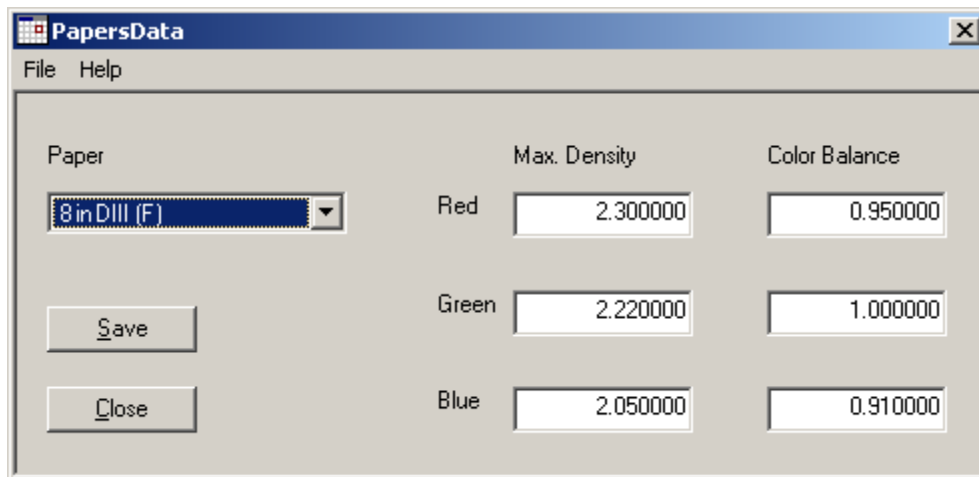

Select the desired paper from the drop-down list and adjust the “Max. Density” and “Color Balance” as needed. Click **Save**, and then **Close**.

The values shown above are for KODAK PROFESSIONAL Digital III Papers. Different values will be required for new paper types as they are introduced.

Activate the box **with Laser point**.

Upon first calibration of a paper, the PBL is automatically printed with laser point if the cassette code indicates that a paper is used for the first time.

Printing an MBL Test

When it is necessary to print an MBL test, follow these instructions.

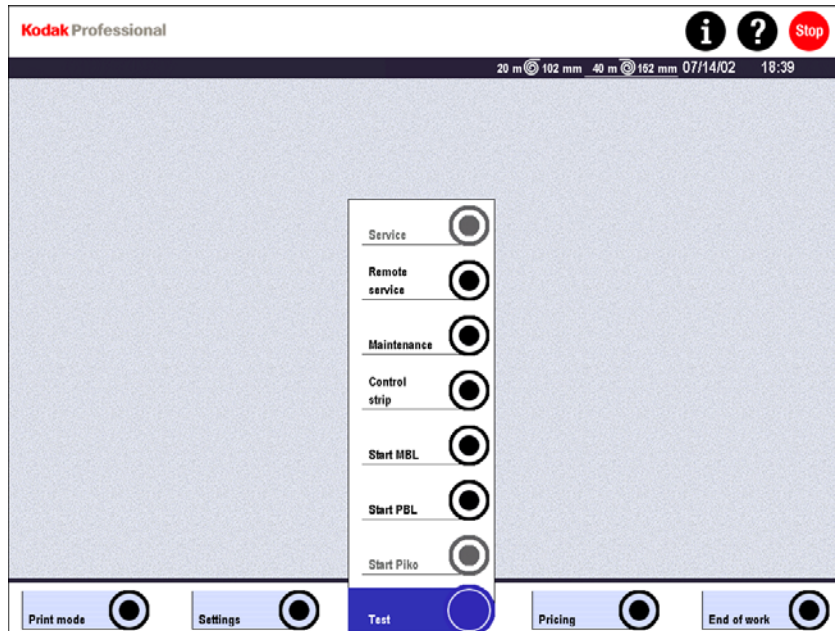

Touch:

- **Test**
- **Start MBL**

An Info screen opens during the test.

If the master paper is not inserted when an MBL is started, you are prompted to insert the master paper.

You can use the **Settings** menu (see Chapter 4) to set up how often the automatic MBL should be repeated if the values continue to be out of tolerance after retries. The number of retries can be from 1 to 10.

Procedure for the First Machine Operation or After New Software Installation

1. Use the predefined paper configurations or set up configurations as required (see Chapter 4).
2. Define the master paper. (This is the paper style most frequently used in the lab.) Touch **Settings – Machine settings – Printer**.

IMPORTANT: Another paper might be entered as the master. After a new software installation or data transmission from a previous version, the first PBL defines the master paper by default. If the master paper is changed, an MBL will be printed automatically.

3. Print a PBL calibration.
 - The **PBL** MUST be printed on the master paper; this is the most frequently used paper in the lab. It is used for the MBL.
 - Activate with Laser point.
4. Print an **MBL** (if this was not done automatically as described above).
5. Print a **PBL** for all other paper styles to be used. This should be printed immediately after the MBL is printed, because the conditions for printer and paper processor during these tests should be the same. The PBL is automatically printed with laser point if the cassette code indicates that a paper is used for the first time.
6. The printer is now calibrated for all paper styles. You can now start the production process.
7. After the PBL has been printed for all paper types, make a database backup so that the values can be loaded back into the equipment, if needed.

See *Save/Load Settings and Configurations* in Chapter 4, *Settings*.

Daily Calibration With the MBL

The **MBL** should be printed directly after system start (as soon as the chemicals have reached their nominal temperatures) and should be repeated once or twice during the day.

For an MBL, the master paper must always be inserted. If an Auto-MBL is to be printed after system start, the master paper must be inserted the night before.

The MBL calibrates the master paper again and all other paper styles are adapted according to the master correction.

In the following print operation, the MBL is the means to keeping the production stable and uniform. This provides consistent, every day compensation for chemical fluctuations and/or changes in the paper process.

- Before running a **PBL** on a paper (for example, because of a new emulsion) perform an MBL on the master paper. In other words, only print a PBL in a calibrated system.
- Perform an **MBL** with the old emulsion if the emulsion is still available.
- If there were changes in the master paper emulsion, run a PBL without laser point.

Daily Calibration Without the MBL

NOTE: Daily calibration without the MBL is the exception.

For the respective paper that is needed, a PBL is printed or repeated, if necessary. This can always be a PBL without new laser point calibration (with the exception of the first time).

Daily calibration without the MBL is possible:

- When using paper styles at the same time which are quite different (for example, paper styles of different manufacturers). In this case, the MBL corrections cannot show exactly the same effect for all papers.
- Only very few paper channels are used.
- If the required conditions for working with the MBL cannot be met.

Calibration of New Paper, Emulsion Changes, or Correction of a Paper Channel (Not Master Paper)

1. Print an MBL.
This provides for a calibrated condition of the system.
2. Print the PBL right after the MBL:
 - With laser point for new papers other than the master paper
or
 - Without laser point if there was an emulsion change only

Calibration of New Paper, Emulsion Changes (Master Paper)

1. Print the MBL on the previous (old) emulsion.
This provides for a calibrated condition of the machine.
2. Immediately print a PBL without laser point on the new master paper.

NOTE: If the old emulsion was used up before an MBL could be printed, the calibration of the new paper can only be started with a PBL calibration. However, in this case be sure that the equipment is calibrated. Otherwise, there may be a deviation between the master paper and all other papers. If this is the case, perform a complete new calibration.

Completion of the New Calibration

If there is too much deviation in the paper styles, a new calibration is recommended.

1. Print an MBL on master paper
2. Immediately print a PBL without laser point for all papers other than the master paper.

After manipulations on the laser module or after changing the chemicals, a new calibration is recommended:

1. Print a PBL with laser point on the master paper.
2. Print an MBL.
3. Immediately print a PBL with laser point for all papers other than the master paper.

Testing the Paper Processor

To maintain or restore optimum processing quality, the chemicals of the paper processor should be checked every day by means of the pre-exposed control strips.

Prerequisites:

- The following working temperatures must have been reached:
 - DEV 40 °C
 - BX 38 °C
 - STB 37 °C
 - Dryer 65 °C
 - There is no order in process.
 - Use KODAK PROFESSIONAL Pro Strips for Process RA-4 (Catalog No. 129 8587).
1. Check that the processing temperatures have been reached.
 2. Unlatch and remove the control strip box (1) from the lane distributor.
 3. In the darkroom, insert a chemical control strip into the control strip box.

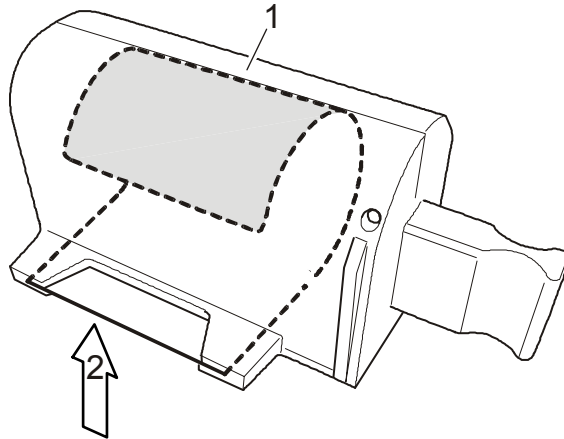

- 1 Control strip box
- 2 Emulsion side / photographic layer

- With the handle of the control strip box to the right and the emulsion side (2) down, first insert the trailing end of the control strip (end that comes out last goes in first). The end of the control strip should be flush to the end of the box
- If the control strip was accidentally inserted upside down (the emulsion is on top), the processed control strip usually shows typical dirt marks.

4. Touch:
 - **Test**
 - **Control strip**
 - **Chemical control strip**You receive a prompt to insert the chemical control strip.
5. Place the control strip box in the holder provided for this in the lower area of the lane distributor.
6. Close the printer door.
7. Touch:
 - **Continue** (to transport the control strip into the paper processor), or
 - **Cancel** (to terminate the operation)
8. Evaluate the process control strips.

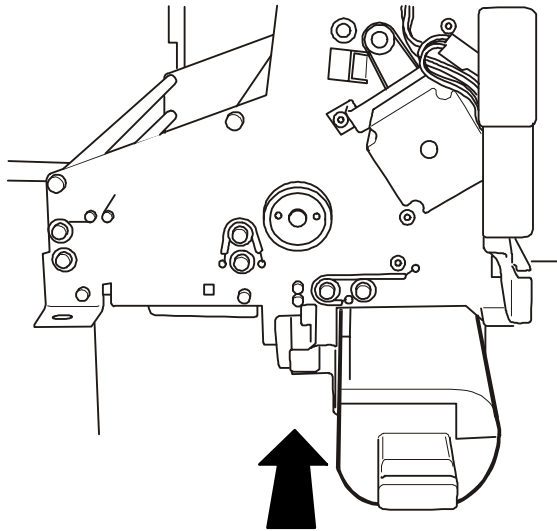

Chapter 6 Production

Contents

Preparing the Equipment for Different Orders	6-3
Preparing the Paper Magazine.....	6-3
Putting Paper in the Magazine	6-5
Coding the Paper Magazine	6-6
Paper Widths Not Yet Coded	6-7
Changing the Paper Magazine	6-8
Order Processing	6-9
Order Number (Automatic / Manual)	6-9
Manual Order Number.....	6-9
Automatic Order Number.....	6-9
End of Order (Automatic / Manual).....	6-10
Print Modes	6-11
Printing File Print.....	6-12
Prerequisites.....	6-12
dTFS.....	6-13
Selecting the Configuration Type for an Order.....	6-14
Single or Package	6-14
Reproduction	6-15
Using Autosave to Save Processed Images without Printing	6-15
Black-and-White or Sepia Prints	6-15
Changing the Configuration and the Order Number	6-16
Displaying the Current Configuration	6-16
Changing the Current Configuration.....	6-16
Selecting a Different Configuration.....	6-17
Changing the Order Number	6-17
Loading Image Files from Data Carriers	6-18
Saving Digital Orders	6-19
Loading Saved Digital Orders	6-19
Printing File Prints without Preview	6-20
Printing File Prints with Preview	6-21
Image Editing and Special in All Print Modes with Preview	6-22
Image Editing.....	6-22
Color / Density Corrections	6-22
Cropping	6-22
Image Improvement.....	6-23
Special (Text)	6-23
Saving Processed Images as Files	6-24
Images in the Network.....	6-24

Network Orders	6-25
Operator-Controlled Start.....	6-25
Automatic Start	6-26
Printing Network Orders.....	6-26
Finishing Print Orders	6-26

Preparing the Equipment for Different Orders

Preparing the Paper Magazine

Paper widths in the paper magazines are 216 to 305 mm (3.25 to 12 in.). The paper magazine must be adjusted to the paper width in use to ensure correct paper transport in the paper magazine.

1. Open the empty magazine and remove the core.
2. Remove the screw for the paper guide holder with a Phillips screwdriver.

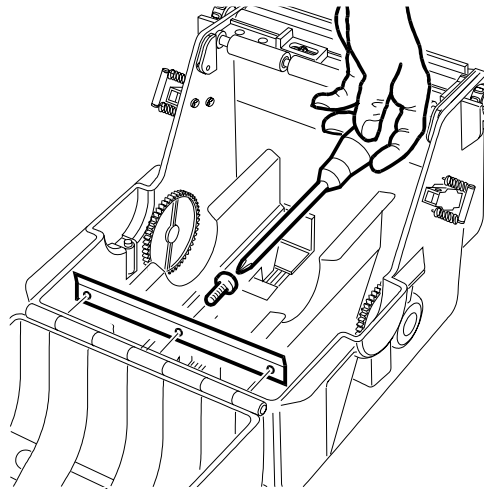

3. Insert the four fingers of the paper guides in the notches corresponding to the paper width. Check that all four fingers are in the correct notch.

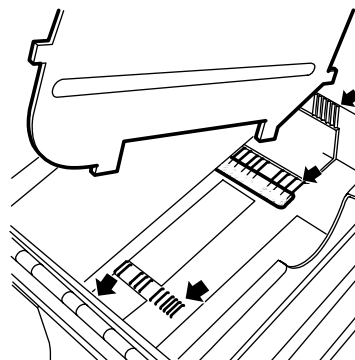

NOTE: The structure of the notches helps to find the correct position.

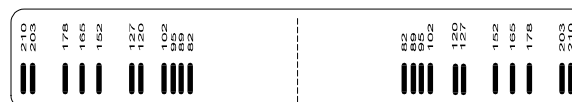

4. Loosen the guide screws on the magazine exit.
5. Move the guides to the correct width.

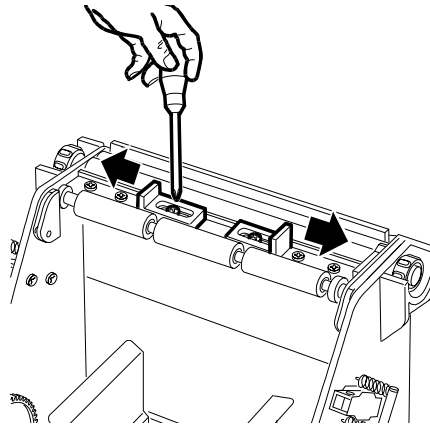

6. Adjust the guides in the other section of the magazine in the same way.

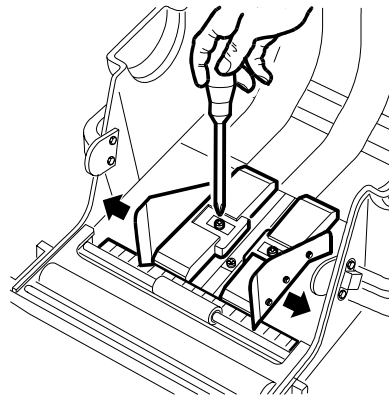

NOTE: If several paper types are used, we recommend preparing several magazines for each paper width.

Putting Paper in the Magazine

Photographic paper must always be stored in a cool and dry place. The best storage temperature is 2 - 10°C (36 - 50°F).

1. Take the paper out of the cool storage at least 24 hours before use so that any condensation on the paper dries.
2. In the darkroom, take the paper roll out of the package and push the core through the roll.
3. Put the paper in the magazine and observe the winding direction (see the figure below).
4. Pull the leading paper edge through the two brackets on the magazine outlet.
5. Pull the paper slightly out of the magazine. Hold the paper with one hand and close the magazine with the other hand.

IMPORTANT: *Avoid fogging of the leading paper edge.*

6. Rewind the paper after closing the magazine by rotating one of the gears on the side of the magazine opening until the magazine latch locks.

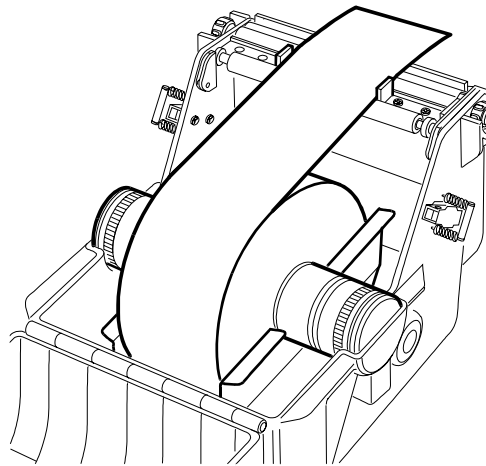

Coding the Paper Magazine

Set the paper magazine coding to the desired paper width and surface as indicated on the sticker. The coding is defined in the table below.

- Slide closed
 Slide open

Paper Width	Width Indicators				Surface Indicators	
	1	2	3	4	5	6
3.25 inch (82 mm)	<input checked="" type="checkbox"/>	<input type="checkbox"/>	<input checked="" type="checkbox"/>	<input type="checkbox"/>		
3.50 inch (89 mm)	<input checked="" type="checkbox"/>	<input type="checkbox"/>	<input checked="" type="checkbox"/>	<input checked="" type="checkbox"/>		
3.75 inch (95 mm)	<input type="checkbox"/>	<input checked="" type="checkbox"/>	<input checked="" type="checkbox"/>	<input checked="" type="checkbox"/>		
4.00 inch (102 mm)	<input checked="" type="checkbox"/>	<input checked="" type="checkbox"/>	<input checked="" type="checkbox"/>	<input type="checkbox"/>		
4.75 inch (120 mm)	<input checked="" type="checkbox"/>	<input checked="" type="checkbox"/>	<input type="checkbox"/>	<input checked="" type="checkbox"/>	GLOSSY	<input checked="" type="checkbox"/> <input type="checkbox"/>
5.00 inch (127 mm)	<input checked="" type="checkbox"/>	<input type="checkbox"/>	<input type="checkbox"/>	<input checked="" type="checkbox"/>	MATTE	<input checked="" type="checkbox"/> <input checked="" type="checkbox"/>
6.00 inch (152 mm)	<input checked="" type="checkbox"/>	<input type="checkbox"/>	<input type="checkbox"/>	<input type="checkbox"/>	CUSTOM1	<input type="checkbox"/> <input checked="" type="checkbox"/>
6.50 inch (165 mm)	<input type="checkbox"/>	<input checked="" type="checkbox"/>	<input checked="" type="checkbox"/>	<input type="checkbox"/>	CUSTOM2	<input type="checkbox"/> <input type="checkbox"/>
7.00 inch (178 mm)	<input type="checkbox"/>	<input checked="" type="checkbox"/>	<input type="checkbox"/>	<input checked="" type="checkbox"/>		
8.00 inch (203 mm)	<input type="checkbox"/>	<input type="checkbox"/>	<input checked="" type="checkbox"/>	<input checked="" type="checkbox"/>		
8.25 inch (210 mm)	<input type="checkbox"/>	<input checked="" type="checkbox"/>	<input type="checkbox"/>	<input type="checkbox"/>		
8.50 inch (216 mm)	<input type="checkbox"/>	<input type="checkbox"/>	<input type="checkbox"/>	<input type="checkbox"/>		
10.0 inch (254 mm)	<input type="checkbox"/>	<input type="checkbox"/>	<input type="checkbox"/>	<input checked="" type="checkbox"/>		
11.0 inch (279 mm)	<input type="checkbox"/>	<input type="checkbox"/>	<input checked="" type="checkbox"/>	<input type="checkbox"/>		
12.0 inch (305 mm)	<input checked="" type="checkbox"/>	<input checked="" type="checkbox"/>	<input type="checkbox"/>	<input type="checkbox"/>		

NOTE: The table shows the Kodak standard. If necessary, change the switch allocation for the paper widths and surfaces. See *Paper Widths Not Yet Coded* on the following page. A maximum of four different surfaces can be used equally for all widths. This concerns only the surface names and the coding. Chemically, the surfaces need not be equal for the different paper widths because the PBLs are created and saved independently of each other for each single combination of all 6 switches.

When the magazine is in place, the system recognizes the paper width and paper surface, and offers them for selection in the print menus.

For more information, see *Defining Surfaces* and *Defining Paper Settings* in Chapter 4.

Paper Widths Not Yet Coded

NOTE: If there is no free magazine code available for a paper width not yet coded, use the code of an unused paper width (we recommend using 82 mm).

To change the code:

1. Delete the width in configurations with width 82 (select **Settings, Machine Settings, Paper Settings**).
2. Use **New** to store the old code of the 82 mm paper for the new paper width. Create configurations with the new paper width (for example, with a cut length of 171 mm).

Changing the Paper Magazine

IMPORTANT: *To let the paper to rewind into the magazine, always wait 30 seconds after the last print procedure before removing the magazine.*

The LED in front of the magazine indicates if the magazine may be removed:

Green: yes

Red: no

1. Remove the paper magazine:
 - a. Push the locking lever to the side.
 - b. Pull out the paper magazine.
2. Mount the paper magazine:
 - a. Open the Printer door.
 - b. Put the paper magazine on the guide rails and push it in until it locks audibly.

IMPORTANT: *In order to avoid paper transport problems due to an incorrectly cut paper tip, confirm the prompt in the next step when:*

- *You have inserted a new paper roll, or*
- *There is a paper jam*

3. If necessary, confirm the prompt for a paper cut.

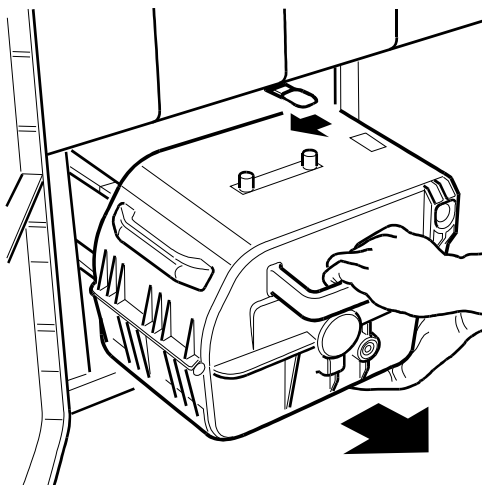

If the cut is confirmed, the equipment cuts the paper tip (4.75 in.) and transports it through the paper processor.

IMPORTANT: *Whenever a magazine is inserted, the system checks the paper length by moving the paper to the cutter and back. To prevent the paper from becoming fogged, make sure the middle printer door remains closed during this procedure.*

Order Processing

Order Number (Automatic / Manual)

Order numbers are allocated either automatically or manually.
See *Machine Settings / Other Settings* in Chapter 4.

Manual Order Number

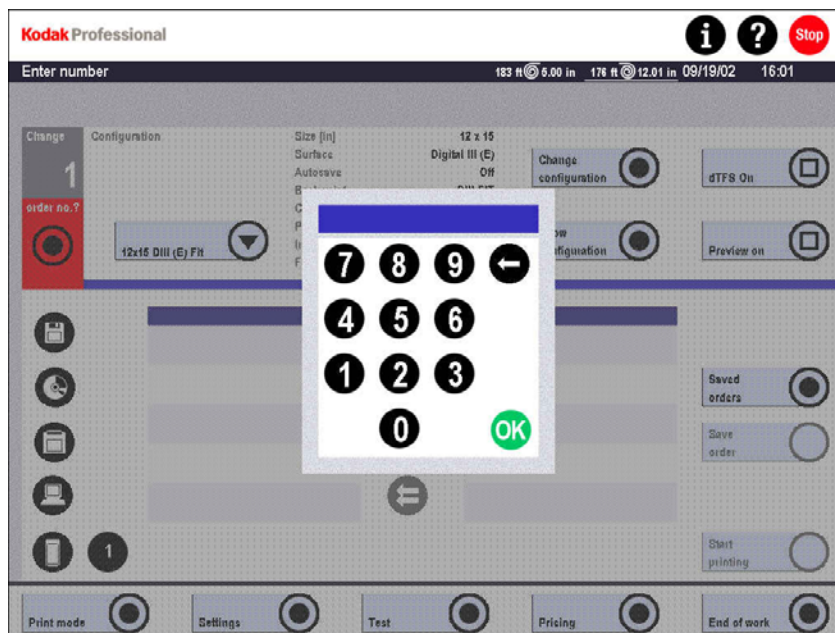

The first order always starts with **1**.

An order number is displayed for every print screen. The number can be changed:

- As long as the **Change?** button is shown under the order number
- Until **Start print** with/without preview is pressed (load image data from data carrier)

Enter a number. If the number already exists, you receive an inquiry as to whether to overwrite the order. The number you enter is incremented for each order that follows.

Automatic Order Number

The first order always starts with **1**. The entered number is automatically incremented for each order that follows. The number cannot be changed.

End of Order (Automatic / Manual)

The orders are completed by end of order. The sorter moves so that the prints are separated in the trays according to the orders.

If an image file is loaded after order end, this new order receives a new order number either automatically or manually. Exceptions:

- The sorter moves on without an end of order if an order exceeds the capacity of one bucket.
- Splices in the paper rolls are cut separately and the respective pieces of paper are deposited in the print order stack.

An automatic end of order occurs:

- When you change to another print mode
- When the **film Stop** key on the screen is touched

Touch the **End of order** button to initiate a **manual end of order**.

Print Modes

With the RP 30 Laser Printer, you will use one of two print modes.

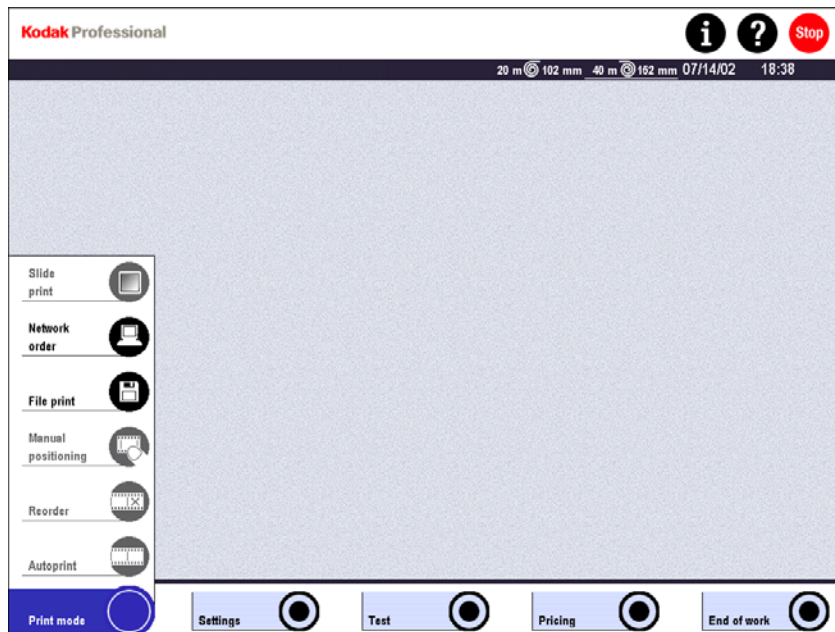

- **File Print:** image files (jpg, bmp, tif) are loaded from mobile data carriers and printed on the RP 30 Laser Printer with or without a preview. The following drives are provided on the main computer: Diskette, DVD/CD-ROM, Zip, and PCMCIA card.
- **Network orders:** Digital orders completely prepared on a workstation are sent by way of a network to the RP 30 Laser Printer to be printed. The start is either automatic (during times when there is no operator action) or operator-initiated.

NOTE: Only one print mode can be used at a time. It is not possible to open several windows concurrently for different print modes.

Printing File Print

Prerequisites

- The RP 30 Laser Printer only accepts jpg, bmp and uncompressed tif file formats. Save any files created with Adobe Photoshop to one of these formats.
- Digital cameras have Gamma values between 1.8 and 2.2. The RP 30 Laser Printer prints with a Gamma of 1.8.
- The maximum single file size is 110 MB (tif, bmp, jpg unpacked). Larger files will not print.
- Adjust the print size to the aspect ratio of the image (indicated by x **pixels**). For extreme deviations, which the program can no longer process, the system displays the error message **File print parameter range violated**.
- Types of image/paper adjustment:
 - Fit image to paper
 - Fill print size
- The quality of the prints depends on the relationship between resolution and print size. The minimum acceptable resolution is approximately 100 pixels per cm (200 pixels per inch).

IMPORTANT: *For images created with Adobe Photoshop:*

- *Save files in tif, bmp, or jpg formats.*
- *Use a Gamma value of 1.8.*
- *Convert CMYK (additive colors) to RGB (subtractive).*

dTFS

The dTFS function is used to compensate for the different characteristics of digital cameras (for example, to correct color casts analog to negative film).

Activate this function only if at least five exposures were made with the same camera. The exposures are combined in a series—similar to film—and the dTFS determines the color and density corrections for every image.

The gray condition does NOT apply. 100/100/100 must no longer result in a gray print.

Gray condition:

In contrast to negatives, the image files have an absolute color allocation:

0/0/0	=	black
100/100/100	=	gray
255/255/255	=	white
255/0/0	=	extreme blue, etc.

Deactivate **dTFS** (the respective information should be recorded at order input) for:

- Manipulated, artificially modified digital exposures
- Images created with graphic programs
- Images with unknown type of creation
- Images taken with different cameras
- Images with "real" white areas (for example, business cards)
- Orders with less than 5 frames

Activate **dTFS** for:

- Images taken with one camera, for example, if the storage medium of the camera is used
- Orders with at least 5 exposures (below 5 exposures, the dTFS has no effect)
- Images with "amateur-like" characteristics
- File Print

Selecting the Configuration Type for an Order

Three types of order configurations are available for file prints. They are represented by a letter in the list of order configurations:

- S** Single
- P** Package
- R** Reproduction

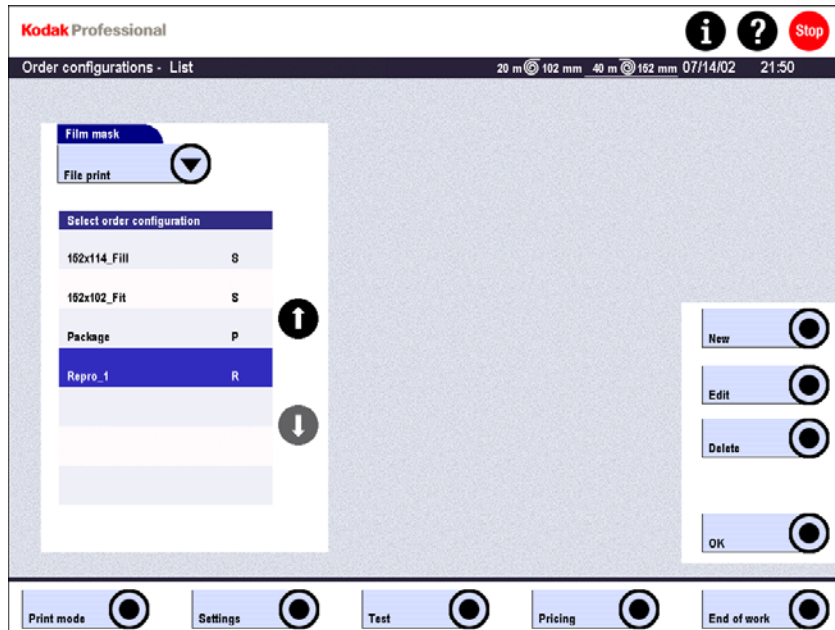

Single or Package

To print an order as single or package, select the order configuration of the respective type. In the list of order configurations, those types are marked as **S** or **P**.

- Single** All prints of the order are printed in the same format.
- Package** A package has several single order configurations combined so that different formats are printed of every image file of an order.

Reproduction

To print a reproduction, select an order configuration of the reproduction type. In the list of order configurations this type is marked as **R**.

Reproduction For images created with programs like Photoshop or shots artificially falsified. The image files of an order are printed without the automatic image improvement and without image size adaptation so that the prints correspond precisely to the original. If there is a difference between image and print size, the result will be a border or loss of image information.

Print without preview The configuration cannot be changed. The image is printed in the middle of a large size (400 dpi), for applications such as CD inlays.

Using Autosave to Save Processed Images without Printing

To save image files without printing, use the order configuration including autosave configurations. All image files of a file print order are stored on the defined local or external drive or sent to the server PC for further processing.

1. Select the order configuration with the required autosave configuration (= storage method).
2. Set the number of prints to zero.

Black-and-White or Sepia Prints

Automatic conversion of color information in the original to black-and-white or sepia is not possible. You must convert the image file externally using a PC and a program such as Photoshop.

Changing the Configuration and the Order Number

Displaying the Current Configuration

Touch **Show configuration**.



- All details about the current configuration and associated sub-configurations as well as all other settings are listed.
- Modifications are not possible in this screen.

Changing the Current Configuration

The selected configuration can be changed temporarily for the current order. The modifications are not saved in the configuration.

NOTE: It is not possible to make modifications to an order that is processing. Modifications can only be entered before the next order is started.

The modifications become effective only after you leave the screen that was opened with **Change Config**.

1. Touch **Change Config**. or select a different configuration in the selection box (see the next title, *Selecting a Different Configuration*).
2. Change the settings as desired and confirm with **OK**. They are not saved, but only apply to the current order/image.

There are different options, depending on how the screen **Change configuration** is opened:

- If the screen is opened before the beginning of an order, modifications hold for all images of the order:
 - Other settings for prints per frame and border, selection of other matching configurations: back print including free text, correction, autosave, front print (IX240) and selection of type of adjustment.
 - For package configurations index layout, autosave, back print including free text

- If **Change configuration** is opened after **Stop** (button in the print modes with preview) or in the enlarged view of an image, the modifications only hold for the current image:
 - Selection of another matching configuration
 - No modification is available for print size or backprint settings

Return to the initial screen by touching **OK** or **Cancel**.

Selecting a Different Configuration

1. Touch the indicated configuration.
The order configurations printable on the inserted paper are marked in the list by an *. A P marks the package configurations.
2. Select the desired configuration from the list.
3. Touch **OK**.

Changing the Order Number

You can change the order number only if **Manual order number** has been selected (under **Machine settings / Other settings**).

1. Touch the **Change?** Button.
2. Enter the desired order number by way of the numeric keypad in the display and confirm with **OK**.

Loading Image Files from Data Carriers

Image files loaded from data carriers are combined in an order. The image files can be loaded from data carriers or from a shared folder in a workstation connected to the equipment. (See *Digital Orders, Settings* in Chapter 4).

The individual images of the order can be edited on the equipment and printed immediately. Or the selection list can be saved and printed later.

1. Open:
 - Print mode
 - File print

When the screen is opened, the defined standard configuration is automatically set.
2. Touch the appropriate drive symbol:
 - Floppy disk
 - DVD/CD-ROM
 - Zip
 - Folder of a workstation
 - PCMCIA
3. If required, select the directory and the sub-directory. Transfer the files in the current (sub-) directory to the previous screen with **OK**.
4. The files available on the selected drive/directory are displayed. Select the files:
 - a. Add all (double arrow) or mark single frames and add (arrow). (All files or individual files can be removed again from the selection list.)
 - b. To enter all image files of an order in the selection list, select other media/directories one after the other and add the desired files, if any. If files with the same name are included in the list, they are numbered continuously (for example, tower, tower-2, tower-3).
5. Touch **Start print** or **Save order**.

The order can be printed at once with or without preview, or it can be saved and handled at a later time.

Also see the following sections:

- *Saving Digital Orders on Page 6-19*
- *Loading Saved Digital Orders (File Prints) on Page 6-19*
- *Printing File Prints without Preview on Page 6-20*
- *Printing File Prints with Preview on Page 6-21*

Saving Digital Orders

1. Touch **Save order**.
2. Enter the name in the next screen and **Save**.

NOTE: Orders that you print immediately and do not save explicitly are automatically stored in a backup directory on the hard disk. This lets you later edit frames of a finished order without much additional work (composing the image files again from the data carriers / directories). If required, you can print again. When the memory is full, you must manually delete backup files that are no longer needed.

Loading Saved Digital Orders

1. Touch **Saved orders** in the File print screen.
2. Check the orders that are not needed any more in the next screen. Mark them and **Delete**.
3. Select the order to be edited and **Load**. Return to the File print screen. All files belonging to the loaded order are listed in the selection list.
4. Add all files to transfer the complete order to the selection list.
5. If necessary, touch the current configuration and select a different configuration from the list or **Change configuration** (for this order).
6. If necessary, change the order number.
7. Activate / deactivate **dTFS**.
8. Activate / deactivate **Preview**.

Printing File Prints without Preview

With preview deactivated, the image files are printed without any other operator intervention because everything has been preset and automated. There are no operations in automatic printing that require a lot of computing time:

- Changing to the print mode with preview is not possible.
- Other actions on the main computer (for example, access to digital images) are not possible.

1. Touch **Start print**.
The digital order is printed automatically. During this time the next order can be prepared.
2. Touch **Finish order**.
Manual end of order is only required if the function Automatic order end is deactivated (see *Machine Settings / Other settings* in Chapter 4).
3. Touch **Prepare order**.
The screen to load image files from data media or stored orders is displayed again.

NOTE: It is not possible to switch to file print with preview while an order is running.

4. After printing:
 - a. Pack the prints and data medium, if requested, in an order envelope.
 - b. Take the prints from the sorter.
 - c. Take the data medium from the drive (DVD/CD-ROM, Zip).

Printing File Prints with Preview

With preview active, a large number of functions are offered for image correction and image enhancement. The edited images can be saved on data carriers.

1. Touch **Start print**.

Up to four images are shown at the same time. The corrections of the selected configuration are taken into consideration. You can modify these corrections for each individual image in the display. Information about the current configuration is shown on the side of the buttons.

Because of capacity limitations, the images in the display have many fewer pixels than the print will have. Lack of sharpness is therefore difficult to discover in the preview.

The preview continues automatically at the preset speed. If the active image (on the extreme right) advances without operator action, it is printed with the preset configuration.

2. If necessary, stop the automatic cycle by touching **Stop**, and edit the active image.

3. Touch **Enlarged view on**.

The current frame is shown twice for comparison:

- Original (small)
- Edited version (enlarged)

If there are modifications, the display is refreshed with the function **Image editing** or **Special**.

4. Touch **Rotate display**.

To show an enlarged picture upright (always by 90° cw).

5. **Enlarged view off** returns to the normal view of the four images.

The same buttons are offered in the view of four images and the enlarged view:

- **Change PpF**

Change the number of prints per frame.

- **Image editing and Specially**

Also see *Image Editing and Specially in All Print Modes with Preview* below.

- **Hold**

All corrections, etc.—except the enlarged view—are kept for all other prints of the order up to the next modification.

- **Print & Stop**

The current frame is printed. It remains marked so that other modifications and further prints can be made.

- **Autoprint (after Stop)**
The current image is printed and disappears from the display. The preview continues.
- **Skip**
The current image is not printed and is not shown any more. The next image moves in from the left.
- **Preview off**
Changing to Autoprint without preview is possible while an order is running. The preview disappears and the remaining images of the order are printed with the preset configuration.

Image Editing and Special in All Print Modes with Preview

In print mode **File print with Preview**, digital images can be edited prior to printing by means of the functions available under **Image editing** and **Special** and saved as image files with **Save**.

Image Editing

Touch **Image editing**.

The button is shown in the preview with four images and in the enlarged view. The opposite screen is displayed. The current image is shown twice for comparison:

- Original (small)
- Edited version (enlarged)

The display is automatically refreshed if modifications are made.

Color / Density Corrections

1. Set Corrections.

The magnified view is refreshed after changing to another slide (for example, from Yellow to density), and 0.2 seconds after a slide has been operated and no other modification was entered afterwards.

2. Touch **OK** or **Cancel**.

Return to the previous screen with / without validation of the modifications.

Cropping

1. Make the Crop selection:
A box is shown for the crop selection. The aspect ratio corresponds to the paper size. The box can be positioned anywhere in the image.
2. Select Crop position.
3. Enter **Crop size** in percent.
4. Validate the setting with **OK** or **Cancel**.
5. Use **Reset Crop** to go back to the complete image information.

Image Improvement

After touching **Improvement**, modify the following parameters:

- Sharpness – edges
- Saturation
- Sharpness – grain
- Detail contrast
- Touch **OK** or **Cancel** to return to the preview images or the enlarged view.

See *Correction Configurations* in Chapter 4. The parameters are described there in detail.

Special (Text)

1. Touch **Special**.
The button is shown in the preview with four images and in the enlarged view.
2. Touch **Text** in the next screen.
3. Touch **Enter text**.
This opens a screen for text input. Type your text select **OK**.
4. Touch **Format text**.
A new screen opens.
5. Select text color and font.
6. Select the font style.
 - a. Touch **B** for bold, **I** for italic and/or **U** for underline.
 - b. Touch the symbol for left justified, centered, or right justified.
7. Select the font size by touching the symbol for reducing or enlarging.
8. Touch **OK** to return to the **Position text** screen.
9. Define the **Text position** by touching the direction arrows.
10. Touch **Place text** to rotate the text in steps of 90°.
11. Touch **OK**.
The **Special** screen appears again.
12. Touch **Border**.
13. Enter the **Width**.
14. Touch **Color** and select a color in the next screen or create a new one (modify the color components).
15. Touch **OK**.
The **Special** screen appears again.
16. Touch **OK** to return to the preview images or the enlarged view.

Saving Processed Images as Files

1. Touch **Save**.
The button appears in the **Image editing** and **Special** screens.
2. Select **File format**, **Resolution**, and the **Drive symbol**.
Edited single images or complete orders can be saved on a diskette, a Zip disk, the hard disk, or in an external directory. File formats are jpg or bmp, with the desired resolution.
3. The **File names** are allocated automatically (for example, image3.jpg). Changes to the file names are possible.
4. Touch **OK**.

Images in the Network

Image data is sent to an external computer or workstation by way of the RP 30 Laser Printer's Ethernet interface, and from there by way of a data network such as the Internet.

Conversely, image data from customers can be received from the external workstation and sent to the RP 30 Laser Printer to be printed, provided suitable software is installed.

Network Orders

RP 30 Laser Printer can be connected with several workstations in the lab by way of a PDM server. These workstations can send completely prepared orders to the equipment for printing at any time. Every one of these orders consists of the corresponding image files and an order description file containing information about the back print text, print size, number of prints/image, configuration, etc.

Supported formats are:

- PFDF (Photofinishing Data Format) for the complete orders
- jpg, bmp, or tif for the single images of a complete order

Because the image editing is already done on the workstation, the orders are automatically printed on the equipment without preview.

The workstation can send orders at any time. The time when the order is to be printed is specified in the **Machine settings**. The RP 30 Laser Printer uses idle times. If you do not perform any operations during a preset time span, the waiting orders are processed in the order of their arrival. Orders requiring a different paper width are skipped. You can start the printing of network orders.

NOTE: A file print configuration with the required paper width must be created beforehand so that the network order can be printed.

Operator-Controlled Start

1. Touch:

- **Print mode**
- **Network orders**

The screen shows an overview of the waiting orders in chronological order. Marking the oldest order is standard.

You can change the order of processing by selecting a different order in the list. It is possible to mark several orders at the same time.

2. Mark an order.

3. Touch **Start Print**.

Automatic Start

With this setting, and after the preset time without operator action has expired, a query window appears asking whether the digital orders should be printed.

You can either ignore this request or respond.

- Respond to the request:
 - No** Print digital orders later
 - Yes** Print digital orders immediately

- Ignore the Request:

The query window is displayed for a certain adjustable amount of time. If there is no response, the digital orders are printed in the order of their arrival. Orders for which another paper width would have to be inserted are skipped.

Printing Network Orders

Each order is printed with the settings in the order description file without operator action.

At the same time, a pop-up with the **Stop** button is displayed. Printing can be stopped at any time while the running order is still finished.

The order just being processed is marked in the order list. As soon as all associated images have been printed, it is automatically cleared from the hard disk and the order list.

Finishing Print Orders

After printing is completed, pack the prints and data medium, if requested, in an order envelope:

1. Take the prints from the sorter.
2. Take the data medium from the drive (DVD/CD-ROM, Zip).

Chapter 7 Correcting System Conditions

Contents

System Errors	7-3
Error Messages	7-3
Reset with the ON Button or Stop Button on the Screen	7-4
Error Handling	7-5
General	7-5
Unresolved Errors.....	7-5
Gray Screen After Reset	7-5
Image Processing Errors	7-6
Paper Processor Errors	7-6
Printer Errors	7-7
Other Error Situations.....	7-7
Help in Case of Error Messages	7-7
Removing Paper Jams	7-8
Paper Jam in the Printer Section.....	7-9
Paper Jam in the Transport Unit	7-10
Paper Transport at the Bottom	7-11
Paper Transport at the Top	7-12
Sheet Bridge to Transport Unit.....	7-13
Transfer/Takeover Sections between Transport Unit and Print Engine	7-14
Paper Jam in the Print Engine.....	7-16
Paper Jam between the Transport Unit and the Lane Distributor	7-18
Paper Jam in the Lane Distributor.....	7-19
Paper Jam between the Lane Distributor and Sheet Transfer	7-20
Paper Jam in the Paper Processor	7-21

System Errors

Avoiding Handling Errors

- CAUTION:** When shutting down the RP 30 Laser Printer, always use the End of Work – Shutdown function. Never switch off the RP 30 Laser Printer with the main breaker because this may:
1. Reduce the service life of the blue/green laser considerably because the laser fan does not remain on to cool the laser.
 2. Cause problems with the main computer. The operating system may need to be reinstalled.
 3. Cause paper jams if not all prints have exited the paper processor.

Error Messages

Error messages can appear in two ways:

1. In the Status line.
These are information or warning messages that do not need to be confirmed. Work can continue in some cases, but the required operations should be performed without delay (for example, refilling chemicals or emptying the effluent tank).
2. In an Error pop-up window.
The work process is stopped. The error must be removed and confirmed by **Clear**. For some system errors, the pop-up window disappears automatically after the error has been cleared.

Reset with the ON Button or Stop Button on the Screen

There are two methods for resetting the system:

- Pressing the **ON** button on the main computer, or
- Touching the **Stop** button on the screen

The advantage of using the **Stop** button is that the laser does not need to be started.

Touch the **Stop** button to initiate a software reset if the system stops responding to operator actions:

1. Transport the paper out and the cancel the current order.
2. Touch the **Stop** button.

The reset pop-up window opens, with **Yes** and **No** buttons displayed.

3. Wait until the paper transport in the printer is empty and all prints are in the paper processor. Otherwise, there will be a risk of a paper jam.
4. Touch **Yes** to initiate the reset.

The system initializes the main assemblies and deletes information concerning previous orders (for example, reorder lists).

Press the **ON** button to reset the system when:

- The whole system must be initialized (for example, when touching the **Stop** button has no effect)
- The selected actions are not executed (lock-up)
- An undefined operating status has occurred

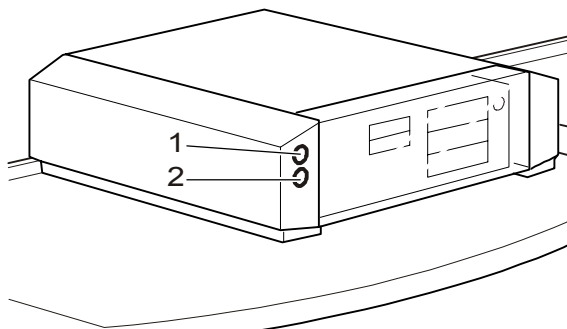

- 1 ON button
- 2 Timer lamp

The database is saved automatically prior to a reset. After the reset, the system starts up again and loads the last consistent backup. The customer does not lose data. The system is in the same status as it was before the **ON** button was pressed.

Error Handling

General

1. Remove errors if the cause is known.
2. Touch **Clear** if this button is shown.
3. If required, touch the **Stop** button on the screen, wait until the paper transport of the printer is empty, and touch **Yes** to initiate a reset. The screen remains gray during the reset procedure. The duration is approximately 3 minutes.
4. If the message **Reset successful** appears, the work can be continued. If not, other actions must be taken.

Unresolved Errors

1. Touch the **i** button to open the error list. All error messages shown in the status line are saved. The list shows the error messages along with the date and time of occurrence.
2. If an error in the paper processor has not been removed, mark the error message and touch **Cancel selection**.
3. Messages of the printer mainly refer to paper that must be removed. Remove the paper.
4. Deactivate **Show all errors** so that only active errors are displayed. Remove and delete all active errors from the list with **Cancel selection**.
5. If the system still does not perform a reset automatically, exit the error list and touch **Stop** to reset the system manually.
6. If the reset is unsuccessful, open one of the two front doors. This makes all relevant error messages visible again. The large error pop-up windows are displayed again.
7. If the loop – constantly unresolved errors – cannot be interrupted, press the **ON** button.

Gray Screen After Reset

If the screen remains gray for more than 3 minutes after a reset, push the **ON** button.

Image Processing Errors

It is possible to have several images that cannot be printed. However, only the last image is shown.

Touch **Clear**.

The types of adjustment for file print are:

- **Fill print**
Center crop; image information getting lost.

- **Fit image to paper**
The complete image information is shown and a border is added.

If **Fill print** is selected, the aspect ratio of the frame must approximately correspond to that of the print size. If there are larger differences, the error message **Parameter range violation** appears. The image can then only be printed with **Fit image to paper**.

Paper Processor Errors

Some errors cause the printer to stop. If paper is still in the transport area of the printer, it must be removed before the work can be continued.

If an error occurs during a reset, a message appears indicating unresolved errors. These active errors must be cleared from the error list.

1. Deactivate the option **Show all errors** to display only active errors.
2. Perform a reset.

Printer Errors

For messages such as:

- **Paper in the Printer**
- **nn_LSxx not reached**
- **nn_LSxx not free**
- **TU2 not ready**

nn = PE, LD, TU

xx = Number of the light barrier

1. Remove the paper from the printer.
Make sure to do this first or consecutive errors may occur.
2. Touch **Clear**.

For messages such as:

- **Shutter not reached (MR, ML)**
- **SG_LS01 not reached**

MR / ML = Magazine RHS / LHS

SG = Sheet Gear

1. Pull back the magazine lever, check the paper for correct position in the magazine, and push in the magazine again.
2. Touch **Clear**.

Other Error Situations

The system stops without displaying a message or the menus cannot be exited.

1. Touch the **Stop** button on the screen.
2. Wait until there is no paper in the printer.
3. Press reset.

Help in Case of Error Messages

Help texts for the error messages can be displayed as follows:

- Touch the **?** button to open the Help screen.
- Touch the **Error Help Index** button to open the alphabetic list of the error messages.
- Select the error message and its associated help text.

Removing Paper Jams

WARNING: *To avoid injury, be careful when working around the toothed belts, sharp corners, and sharp edges in the printer area.*

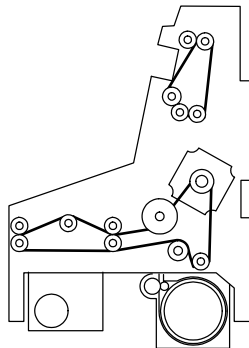

When a paper jam occurs:

1. Remove the paper from the indicated position. To see the location of the jam, touch **i** and the desired module in the graphic.
2. If you cannot find the jam location, do these steps in order:
 - a. Open the bottom transport unit. Wind out up to three prints by hand, some of them from the turnaround roller at the entrance of the transport unit.
 - b. In the switching gear before the transport unit, lift the guide plate (if required) and turn the drive roller by hand to check if there is still a cut paper in the switching gear.
 - c. In the upper transport unit, lift the guide plate and check if paper is underneath.
 - d. Check the entrance and exit of the print engine.
 - e. Check the lane distributor and transfer from the lane distributor to the sheet transfer.
 - f. Check if the paper jam is still reported.
 - g. Pull out the sheet transfer.
 - h. Check the print drum in the print engine. Take out the top guide plate, and turn the print roller forward by hand to move out any paper that may still be inside.
3. When you locate the paper jam, always try to pull the paper out in the direction of the paper advance.

Special Case:

When a paper jam occurs during a system shutdown or reset, the paper jam is only reported when the system is started again. During this time, the Info function is not available. If the paper is not found and cannot be removed, do these steps:

1. Confirm the error message about 5 times. The main menu appears.
2. Touch **i** to open the Info function.
3. Touch the modules in the graphic one at a time to find the locations.

Paper Jam in the Printer Section

If a paper jam occurs in the printer section, any sheets in front of the print engine will not be transported any further. Behind the jam position, all sheets in or behind the print engine are automatically transported into the paper processor.

Remove sheets that are jammed in the printer. The location and the number of sheets can be opened on the screen (touch **i** and touch the respective module in the graphic).

Assembly groups that must be pulled out of the printer to remove the jam are not energized. The printer will automatically be ready for printing again once you have removed the jammed sheets and either cleared the error message or initiated a reset.

Paper Jam in the Transport Unit

CAUTION: If a paper jam occurs, always withdraw the print engine first before pulling out the transport unit.

Pull out the print engine:

1. Open the left-hand side door.
2. Actuate the two levers (1) and open the locking mechanism.
3. Pull out the complete print engine (2).

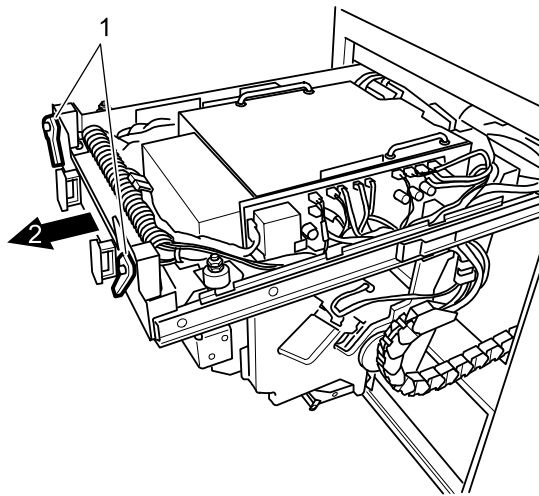

Paper jams may occur in three positions in the transport unit:

- Paper transport at the bottom
- Paper transport at the top
- Sheet bridge

Paper Transport at the Bottom

With the print engine pulled out:

1. Actuate the two levers (1) and open the locking mechanism.
2. Pull out the transfer unit towards you.
3. Open the levers (2) and hold against the unit as the bottom part of the transport releases.
4. Pull the flap (3) up and slowly lower the bottom part.

CAUTION: When you return the flap (3) to the operating position, it must be flush to the side of the transport before you close the lever (2).

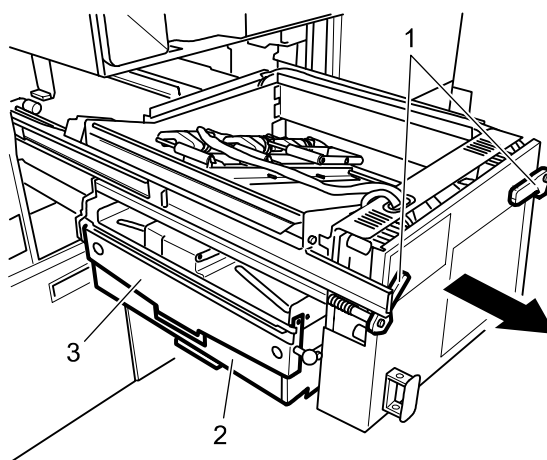

5. Remove the jammed paper from the paper transport.

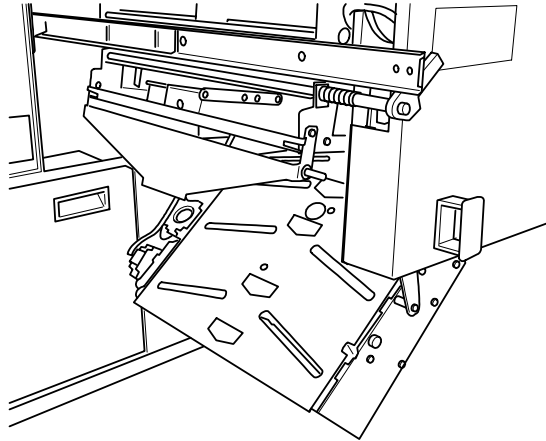

Paper Transport at the Top

With the print engine pulled out, the locking mechanism opened, and transport unit pulled out:

1. Lift the top guide plate on the shafts marked red, and fold it up.
2. Remove the jammed paper from the top paper transport.

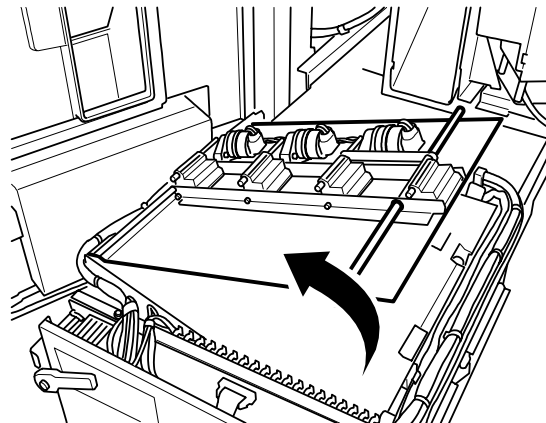

Sheet Bridge to Transport Unit

With the print engine pulled out, the locking mechanism opened, and transport unit pulled out:

1. Open the guide plate for the sheet transport and remove the paper.

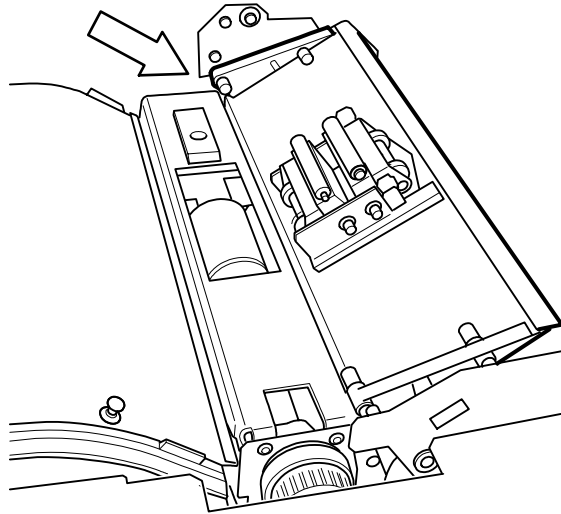

2. Turn the button (see arrow) on the sheet turnover and remove the paper.

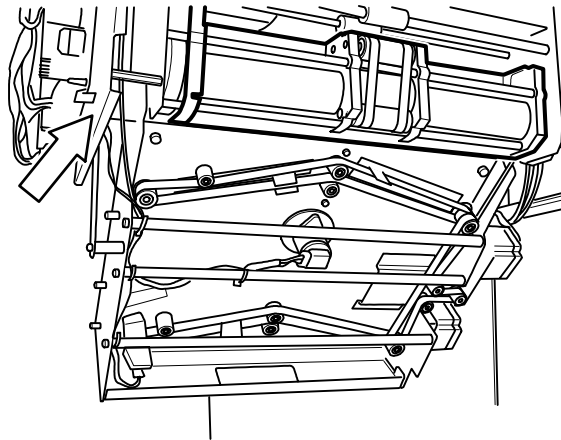

Transfer/Takeover Sections between Transport Unit and Print Engine

Always pull out the print engine first:

1. Open the left-hand side door.
2. Actuate the two levers (1) and open the locking mechanism.
3. Pull out the print engine (2) completely.

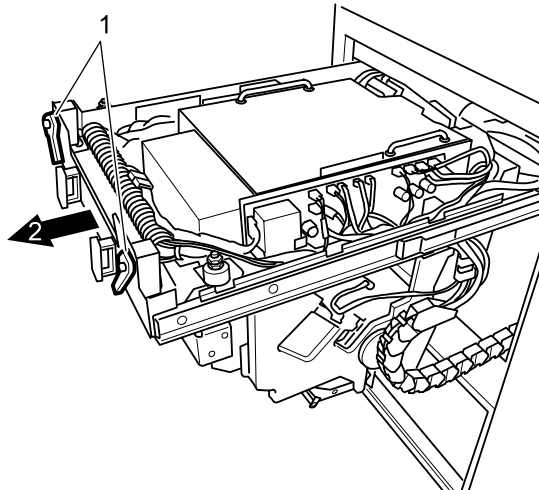

For paper jammed in the print engine:

1. Remove the guide plate at the top (1) and/or the bottom (2), pressing the toggle of the guide plate down (1) or up (2).
2. Remove the paper.

For paper jammed in the transport unit:

1. Leave the transport unit in the printer. Do not pull it out.
2. Remove the paper.

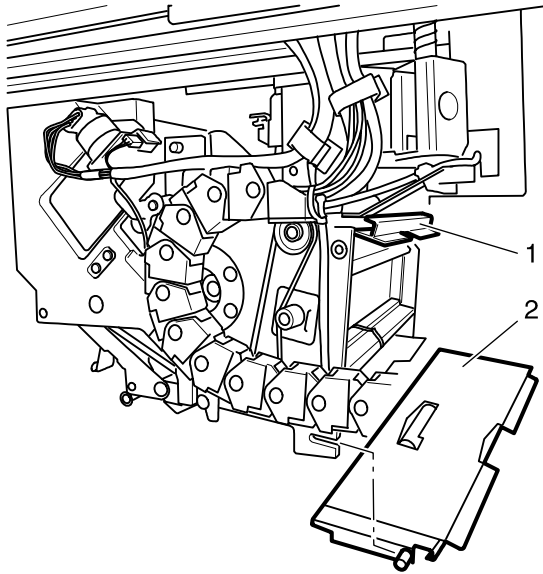

Paper Jam in the Print Engine

1. Pull out the print engine.
 - a. Open the left-hand side door.
 - b. Open the locking mechanism using the two levers (1).
 - c. Pull out the print engine (2) completely.

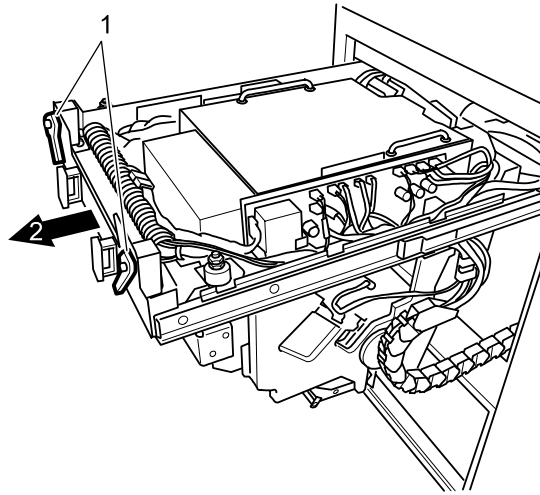

2. Turn the transport belt pulley of the stepper motor for the print drum.

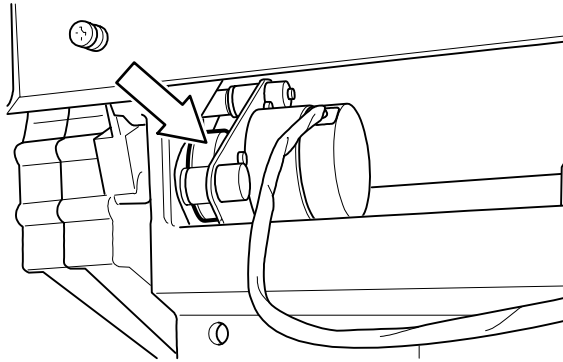

3. Unlock (2) the bottom belt assembly (1) and fold it down.
4. Remove the paper from the print roller (3).
5. Verify that all belts of the lower belt assembly and the print drum sit correctly.

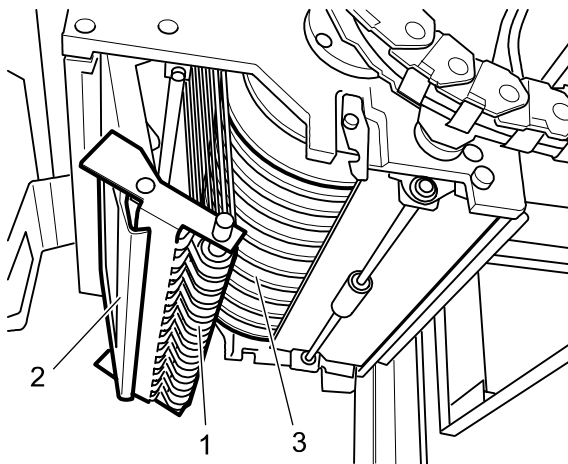

Paper Jam between the Transport Unit and the Lane Distributor

1. Open the right-hand printer door.
2. Open the locking mechanism (fastening screw) and pull the lane distributor out towards you.
3. Turn the hand wheel (1) at least 10 turns to advance the sheet into the lane distributor.

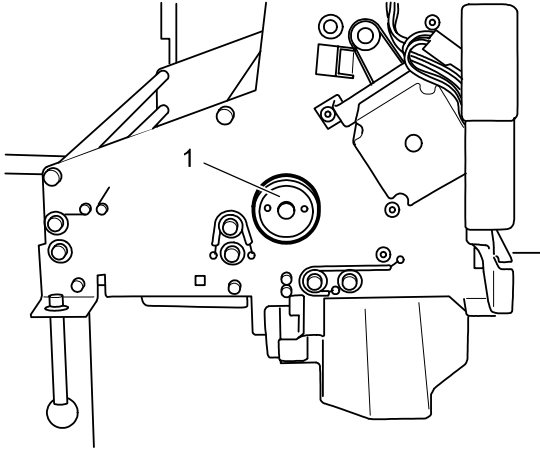

4. Remove the guide plate (1). Pull the 2 push buttons to open them.
5. Remove the paper.

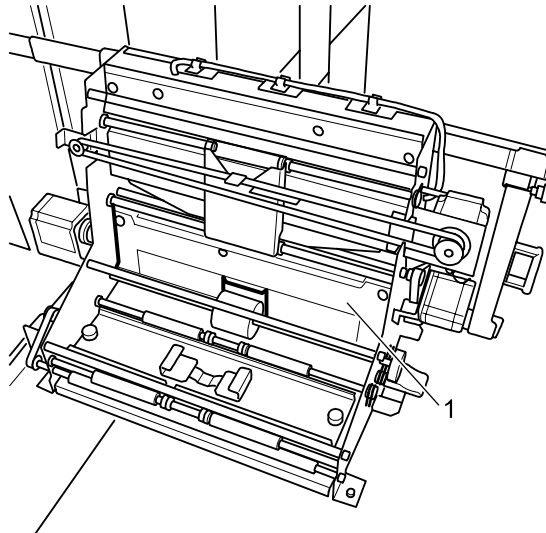

Paper Jam in the Lane Distributor

1. Open the right-hand printer door.
2. Open the locking (fastening screw) and pull the lane distributor out towards you.
3. Pull each of the two push buttons (1) to open them.
4. Remove the guide plates.
5. Remove the paper.

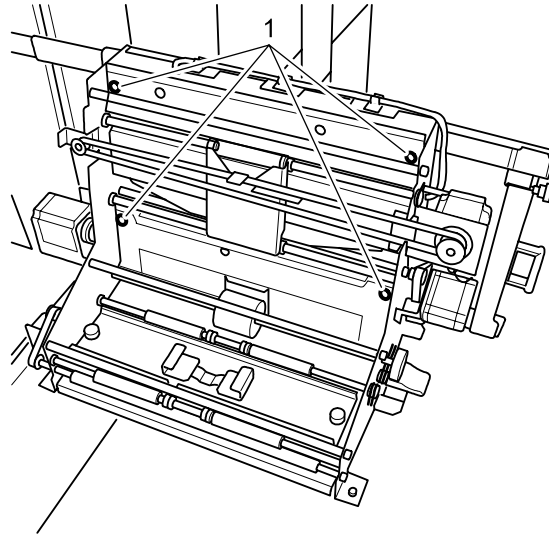

Paper Jam between the Lane Distributor and Sheet Transfer

1. Remove the red fastening screw (1).
2. Remove the cover (2).
3. Hold the sheet transfer by the handle (3). Lift and remove the sheet transfer.
4. Remove the paper.
5. Verify that all belts are positioned correctly.
6. Mount the unit again. Be careful of the two locking bolts (4) on the right-hand side wall.

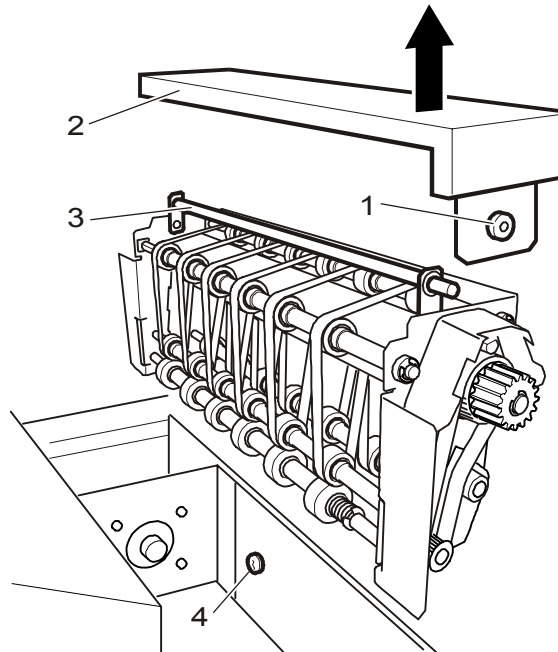

CAUTION: If the paper is damaged (torn, squeezed) when it is pulled out, mechanical damage cannot be ruled out.

Paper Jam in the Paper Processor

WARNING: *Risk of injury is possible if the wet section cover is unlocked unintentionally (when PUSH is pressed).*

- **When opening the cover:**
Check that the cover lock fully engages in vertical position.
- **When closing the cover:**
Support the cover with one hand. Press the unlocking lever (PUSH), and close the cover.
- **Wear protective gloves and goggles when removing jams in the paper processor.**

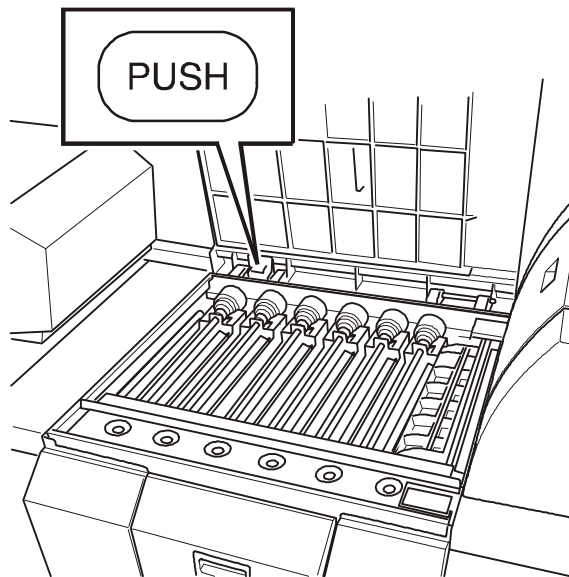

Pull out the racks to remove the jammed paper:

1. Open the cover.
2. Open the rack locking lever.

CAUTION: Chemical splashes may stain the covers. Use the splash guard (1) or remove splashes immediately with water.

3. Remove the CD (Color Developer) feed unit, the tank crossovers and the squeegee unit.
4. The CD solution must not be contaminated by bleach-fix. Therefore, put the splash guard (2) on the CD rack.

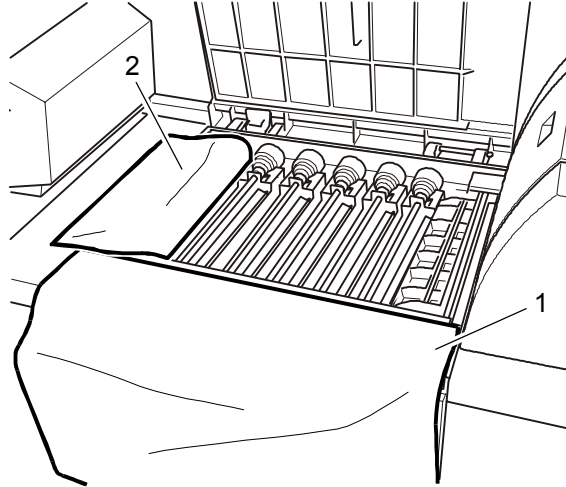

5. Open the rack locks. Lift the racks SB1 to SB4 and let the chemical solution drip from the racks.

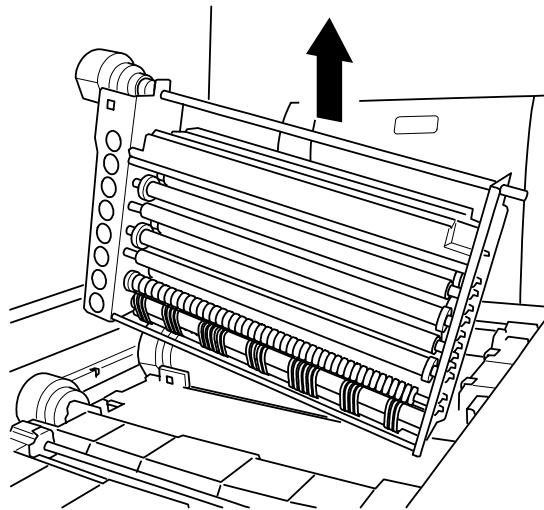

6. Lift the BX (bleach-fix) rack far enough so that the hinged holding plate can rest on the metal bracket to let the chemical solution drip from the rack.

Chapter 8 Maintenance

Contents

Maintenance Schedule and Maintenance Intervals	8-3
Daily Maintenance	8-4
Performing a Process Control for the Paper Processor	8-4
Weekly Maintenance	8-6
Removing Paper Dust from the Printer Sections	8-6
Transport Unit.....	8-6
Single Sheet Buffer and Sheet Bridge.....	8-7
Print Engine	8-8
Lane Distributor	8-11
Sheet Transfer.....	8-12
Cleaning the Paper Processor: CD Feed Unit, Tank Crossovers, and Squeegee Unit and V Wipers.....	8-13
Removing the CD (Color Developer) Feed Unit.....	8-14
Removing the Tank Crossovers	8-15
Removing the V Wiper and Squeegee Unit.....	8-16
Cleaning	8-16
Cleaning the Chemical Filters	8-18
Cleaning the Filters in ASTOR and Water Inlets.....	8-19
Cleaning the Densitometer Calibration Plate	8-20
Cleaning the Transport Belt of the Print Chute	8-21
Monthly Maintenance	8-22
Below the Cutter Unit.....	8-23
Door to Print Engine	8-23
Right-hand Side Wall, Dryer and AC Power Supply of the Paper Processor	8-25
Cleaning the Paper.....	8-32
Cleaning / Replacing the Air Filters	8-32
Cleaning the Guide with the Feed Chute	8-33
Cleaning the Rubber Transport Belts	8-34

Maintenance When Required	8-37
Consumables	8-39
Chemicals	8-39
Air Filters	8-39
Other Consumables	8-39
KODAK PROFESSIONAL Digital III Paper.....	8-40

Maintenance Schedule and Maintenance Intervals

Daily	Weekly	Monthly	When required	Maintenance jobs to be performed by the customer
				Perform process control on the paper processor
				Transport unit: Remove paper dust
				Single sheet buffer and sheet bridge: Remove paper dust
				Print engine: Remove paper dust
				Lane distributor: Remove paper dust / deposits
				Sheet transfer to paper processor: Remove paper dust
				Clean tank crossovers of the paper processor
				Clean CD feed unit
				Clean squeegee and wiper unit (V wipers)
				Check solution levels, top up if necessary
				Clean chemical filters
				Clean filter in ASTOR and water inlets
				Clean densitometer calibration plate
				Print chute: Clean transport belt
				Check solution temperatures
				Clean air filters – Below cutter units – Door to print engine – Paper processor: right-hand side wall, dryer and AC supply
				Replace the chemical filters
				Clean processing racks
				Clean dryer rack
				Clean paper outlet: – Clean / replace air filter – Clean slide plate with feed chute – Clean rubber transport belts
				Change back printer ink ribbon
				Empty effluent tanks

WARNING: *Be sure to observe the safety precautions on all equipment labels and in the Regulatory and Safety section of this manual.*

Do not clean while the drive is switched on.

To avoid risk of injury, be careful when working around the toothed belts, sharp corners, and edges in the printer area.

Daily Maintenance

Performing a Process Control for the Paper Processor

Before performing process control, make sure:

- The nominal processing temperatures of the solutions have been reached.
- There is no order in process.
- You use KODAK PROFESSIONAL Pro Strips for Process RA-4 (Catalog No. 129 8587).

1. Unlatch and remove the control strip box (1) from the lane distributor.
2. In the darkroom, insert a chemical control strip into the control strip box.

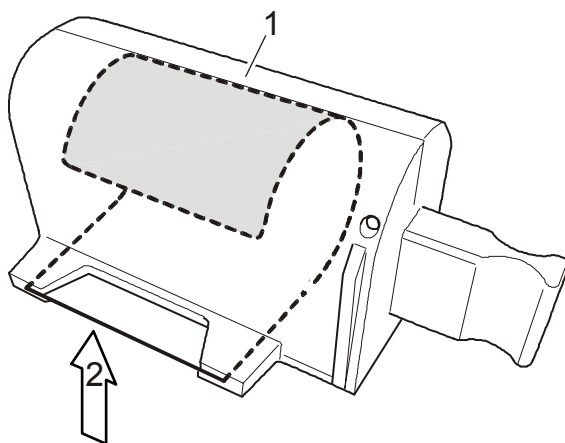

- 1 Control strip box
- 2 Emulsion side / photographic layer

- With the handle of the control strip box to the right and the emulsion side (2) down, first insert the trailing end of the control strip (end that comes out of the control strip bag last goes in first). The end of the control strip should be flush to the end of the box.
 - If the control strip was accidentally inserted upside down (the emulsion is on top), the processed control strip usually shows typical dirt marks.
1. Touch:
 - **Test**
 - **Control strip**
 - **Chemical control strip**You receive a prompt to insert the chemical control strip.
 2. Place the control strip box in the holder provided for this in the lower area of the lane distributor.

3. Close the printer door and touch:
 - **Continue** (to transport the control strip into the paper processor), or
 - **Cancel** (to terminate the operation)
4. Evaluate the process control strips.

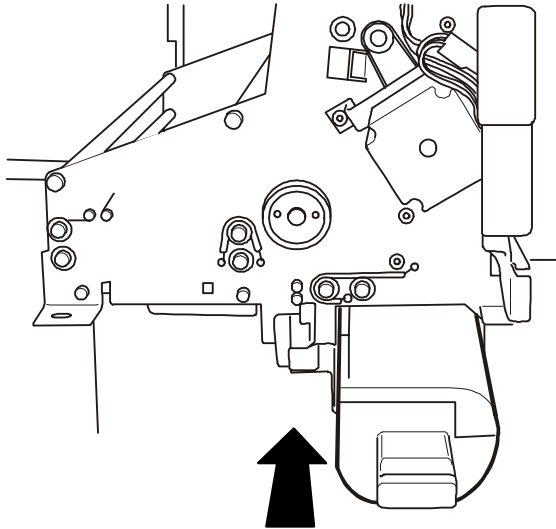

Weekly Maintenance

Removing Paper Dust from the Printer Sections

The necessary tools are:

- Vacuum cleaner
- Brush
- Isopropyl alcohol for plastic-coated and rubber rollers

CAUTION: Isopropyl alcohol is a flammable liquid. It can cause eye irritation and dry skin. Wash your hands with soap and water after you perform maintenance procedures. Refer to the manufacturer's material safety data sheet (MSDS) for additional safe handling and first aid information.

Transport Unit

1. Unlock the transport unit and pull it out on the telescopic rails.
2. Open the transport unit.
3. Remove the paper dust with a vacuum cleaner.
4. Clean the sensors with a brush.
5. Clean the transport rollers.
6. Push in the transport unit and lock it.

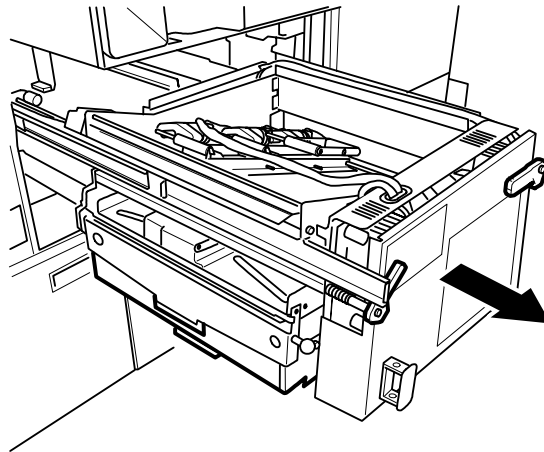

Single Sheet Buffer and Sheet Bridge

1. Unlock the transport unit and pull it out on the telescopic rails.
2. Pull up the quick-action lock (1). Pull the cover plate of the single sheet buffer slightly to the front and remove it.
3. Hold the sheet bridge on the left side and fold it open to the right.
4. Remove the paper dust with a vacuum cleaner.
5. Set the sheet bridge back to its initial position (3) and snap it into the locked position.
6. Push the cover plate of the single sheet buffer (SR) into the holding brackets (2) at the back, and fasten it at the front by snapping in the quick-action lock.
7. Push in the transport unit and lock it.

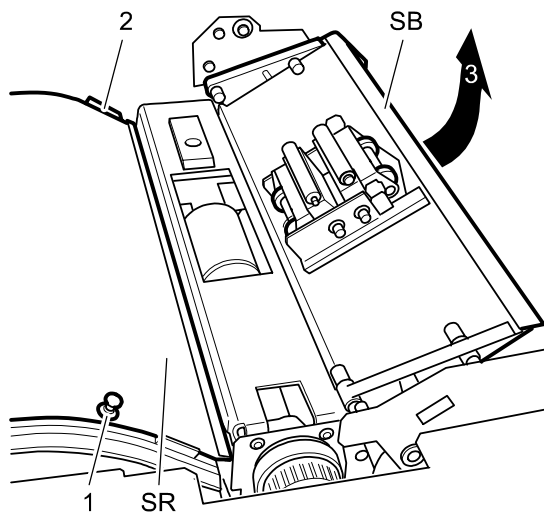

Print Engine

1. Open the locking mechanism (1) of the print engine.
2. Pull out the print engine (2) on the telescopic rails.

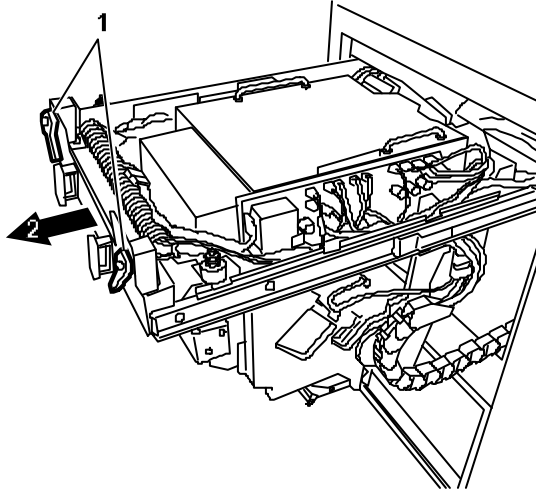

3. Press down the toggle on guide plate (1), press up on guide plate (2), and remove the two guide plates.
4. Remove the paper dust with a vacuum cleaner.
5. Insert both guide plates again.

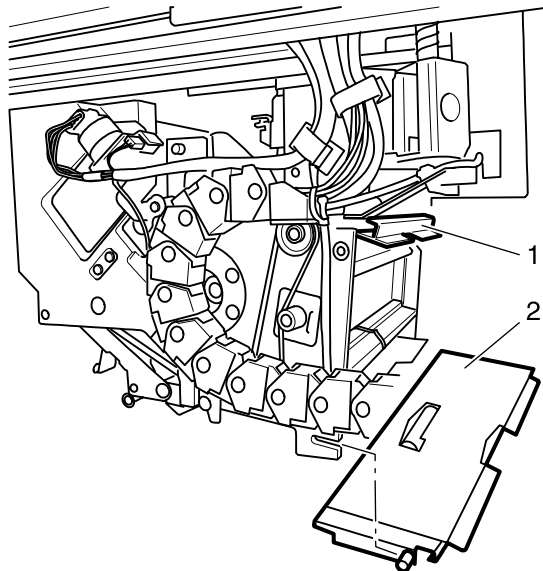

6. Clean the light barriers with a brush or compressed air spray:
- Beginning of Line – BOL (1): Start of exposure (accessible from outside)
 - Beginning of Page – BOP (2): Paper tip detection

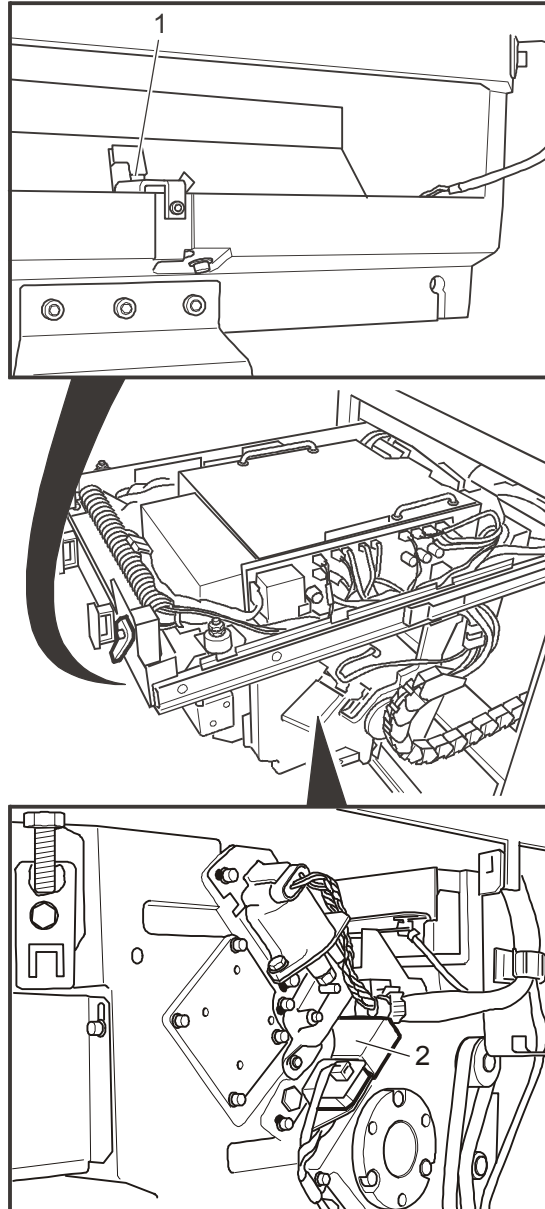

7. Open the belt assembly.
8. Remove the paper dust with a vacuum cleaner.
9. Close the belt assembly again.

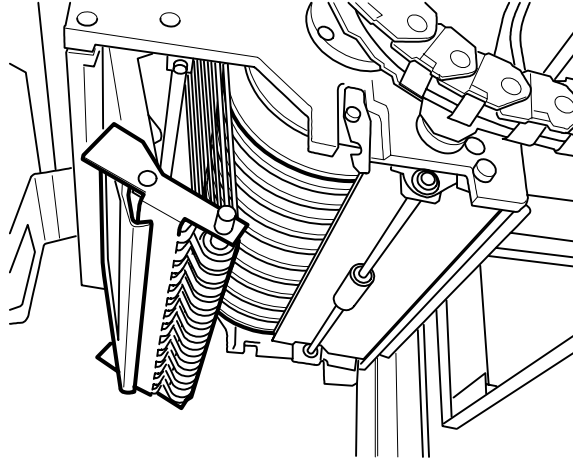

IMPORTANT: *Make sure that the transport belts are not shifted.*

Lane Distributor

WARNING: *Be careful to avoid risk of injury caused by toothed belts that may run in the marked area.*

The purpose of this procedure is to avoid transport problems.

1. Loosen the red locking screw (1).
2. Pull out the unit on the telescopic rails.
3. Remove the paper dust with a vacuum cleaner.
4. Remove the guide plates after opening the quick-action locks (2) and the knurled screws (3).
5. Clean all guide plates with a damp cloth.
6. Put back the guide plates. Check that they sit correctly in the holders and that the quick-action locks are locked.
7. Clean the transport rollers.
8. Push in the unit and tighten the locking screw.
9. Vacuum the cabinet.

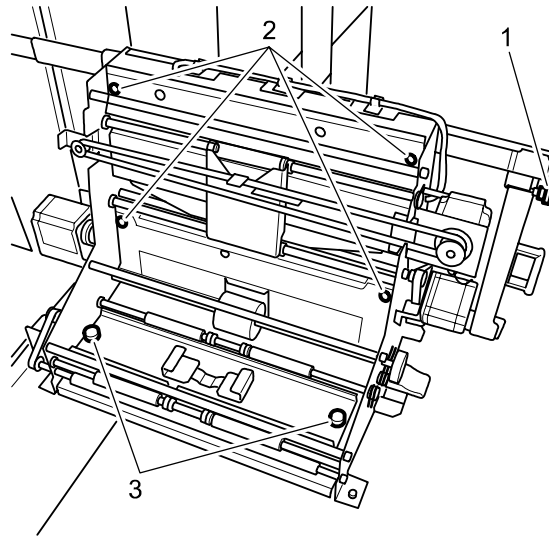

Sheet Transfer

1. After pulling the red latch (1), remove the cover (2) of the sheet transfer.
2. Hold the sheet transfer by the handle (3) and lift the sheet transfer out of the holder.
3. Set the sheet transfer down.
4. Remove the paper dust with a vacuum cleaner.
5. Clean the rollers and transport belts with a lint-free cloth.
6. Mount the unit again.
Note the two locking bolts (4) on the right-hand side wall.
7. Mount the cover by holding the latch in the open position and lowering the cover.

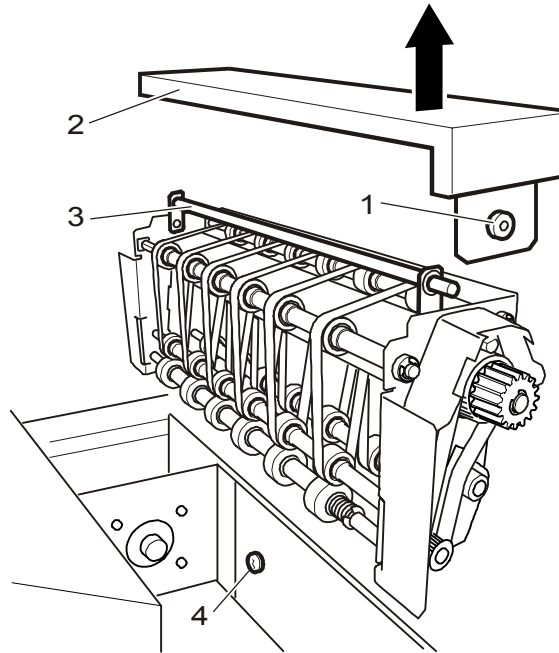

NOTE: Make sure that the transport belts are not shifted.

Cleaning the Paper Processor: CD Feed Unit, Tank Crossovers, and Squeegee Unit and V Wipers

WARNING: Risk of injury is possible if the wet section cover is unlocked unintentionally (when *PUSH* is pressed).

- **When opening the cover:**
Check that the cover lock fully engages in vertical position.
- **When closing the cover:**
Support the cover with one hand. Press the unlocking lever (*PUSH*), and close the cover.

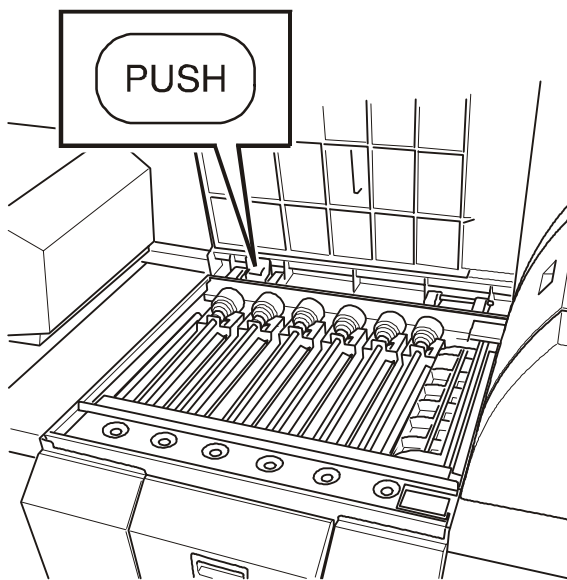

IMPORTANT: To prepare for cleaning, put the crossovers in a lab basin filled with water over the weekend.

CAUTION: To avoid damage to the rollers and paper guide surfaces, do not stack the crossovers.

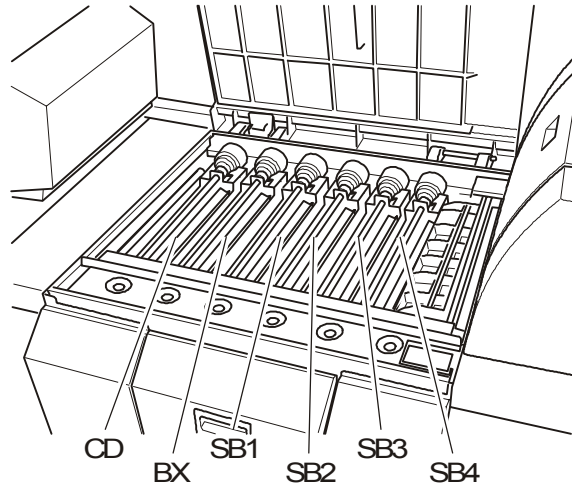

Removing the CD (Color Developer) Feed Unit

1. Open the paper processor cover and let it lock in the vertical position.
2. Fasten the splash guard at the front to protect the tank area from chemical splashes.
3. Release the tabs and grasp the CD feed unit, remove it, and put it in the lab basin.

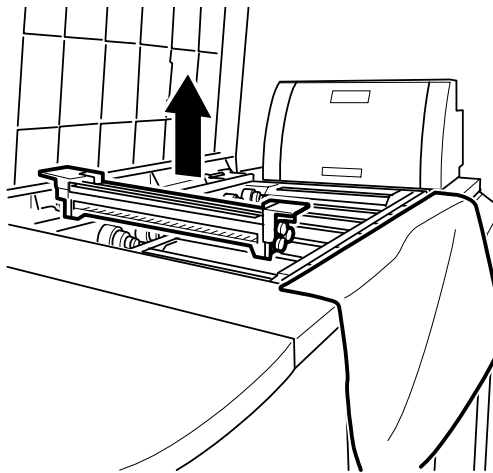

Removing the Tank Crossovers

Working from left to right, put each of the 5 tank crossovers in the lab basin.

1. Grasp the tank crossovers by the tabs.
2. Remove the crossover.
3. Set the crossover in the lab basin.

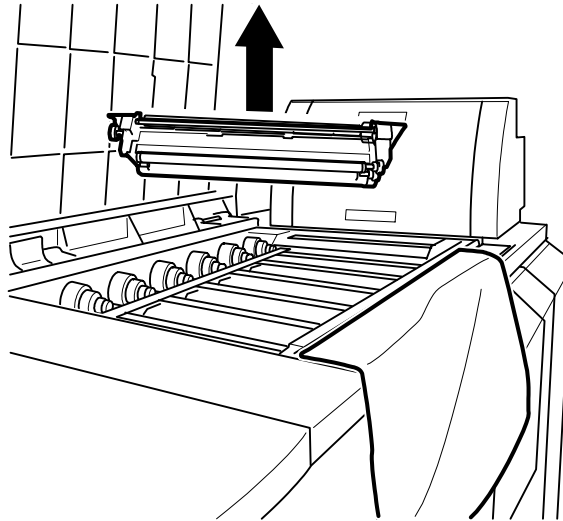

Removing the V Wiper and Squeegee Unit

NOTE: The squeegee unit consists of a guide section and a holder for the V wiper. The holder must be unlocked on both sides to remove it.

1. Grasp the squeegee unit by the tabs and remove it.
2. Unlock the holder for the V wiper on both sides and lift it out of the squeegee unit.
3. Put both parts in the lab basin.
4. Close the paper processor cover.

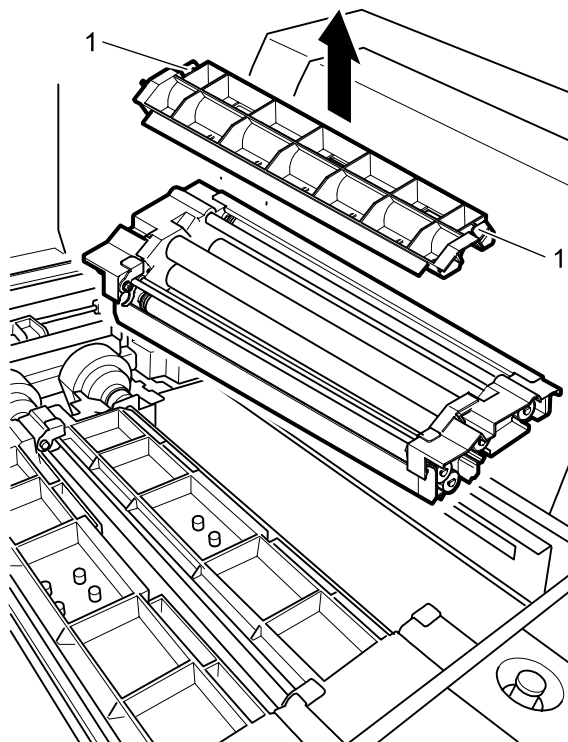

Cleaning

Clean the CD feed unit, tank crossovers, and the squeegee unit and V wipers before starting to work after the weekend.

1. Clean the CD feed unit and tank crossovers.
 - a. Clean the rollers in the lab basin with a soft brush.
 - b. Clean the paper slide surfaces with a lint free cloth.

CAUTION: Do not damage the wiper edges of the V wiper. Check for damage.

2. Clean the squeegee unit and V wipers.
 - a. Clean the rollers of the squeegee unit with a soft brush.
 - b. Clean the paper guide surfaces of the squeegee unit and the holder with a lint free cloth.
3. Reinstall the holder of the V wiper and let it snap in.
4. Rinse the crossovers again in running water before mounting them.

NOTE: Observe the attached color markings / numbering when reinstalling the tank crossovers and the squeegee unit. Check that the latches of the units snap in and are flat against the housing.

Checking the Solution Levels

Purpose: To compensate for evaporation (also required with the automatic evaporation compensation).

Check the solution levels in the paper processor and top up with water once a week before starting production.

If the level drops considerably:

1. Adjust the settings of the water replenishment to the required level.
2. Replace defective level switches (service technician).
3. Search for leaks (service technician).

WARNING: *The risk of fire exists if the level switches become defective. Have defective level switches replaced immediately. Do NOT attempt to repair them.*

Cleaning the Chemical Filters

Purpose: To ensure uniform circulation of the processing solutions by regular cleaning of the filters.

Clean chemical filters:

1. Remove the chemical filters once per week and clean with warm water and a soft brush.
2. Reinstall the chemical filters in the color-marked order.

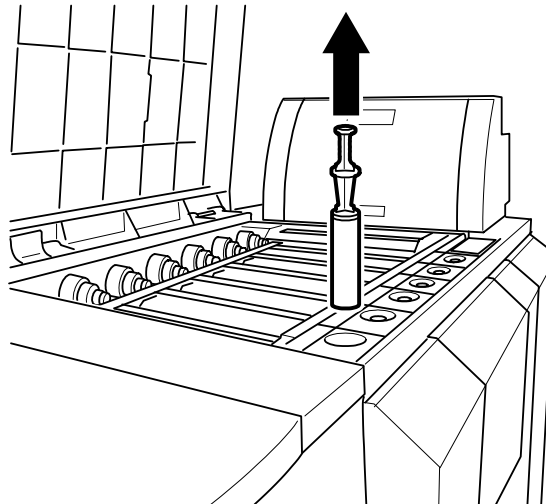

Cleaning the Filters in ASTOR and Water Inlets

IMPORTANT: Close the water tank cover (3) before beginning this procedure.

1. Close the drain valves on the top of the 3 inlets.
2. Unscrew the cap nuts (1 and 2) and carefully remove them.

NOTE: The cap nuts are full of liquid.

3. Remove the filters and rinse them in running water.
4. Reinstall the filters.

IMPORTANT: Do not mix up the ASTOR filters with the water filters.

5. Open the drain valves again.

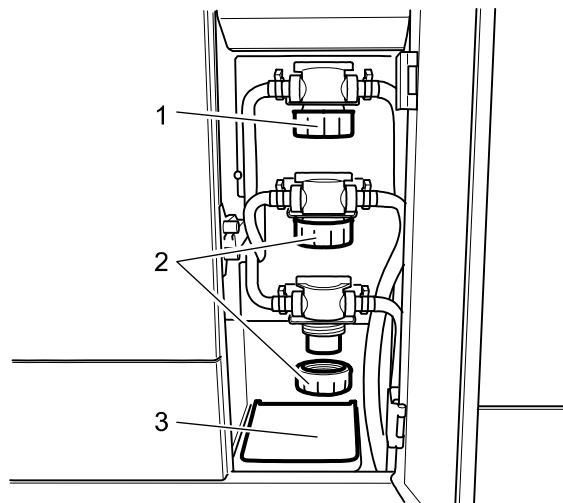

- | | |
|---|-------|
| 1 | ASTOR |
| 2 | Water |

Cleaning the Densitometer Calibration Plate

The densitometer is mounted in the paper outlet.

1. Loosen the screw (2) and remove the front cover of the paper outlet (1).

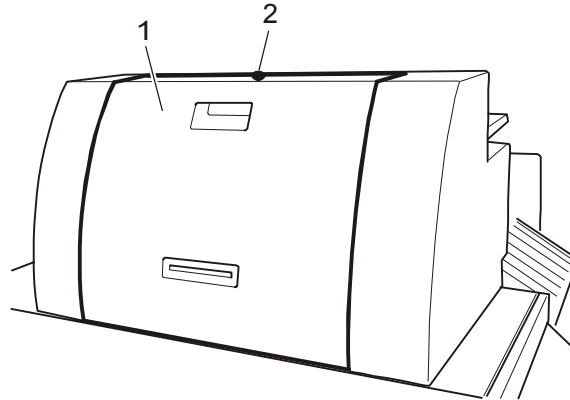

2. Loosen the knurled screws (1) on the right and left side on the guide plate of the densitometer unit.
3. Turn the densitometer unit (2) over and clean the calibration plate with a damp cloth.
4. Clean the guide plates with a damp lint free cloth.
5. Fasten the densitometer unit again with the knurled screws.
6. Fasten the cover of the paper outlet.

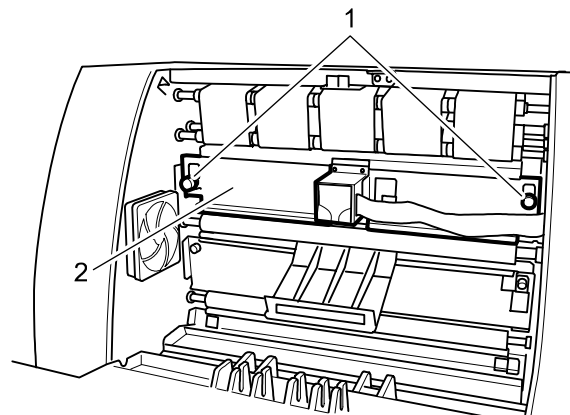

CAUTION: Have a service technician replace any damaged calibration plates.

Cleaning the Transport Belt of the Print Chute

Use a cloth and warm water.

1. Clean the transport belt (1) with a damp cloth.
2. Wipe the print chute (2) with a damp cloth.

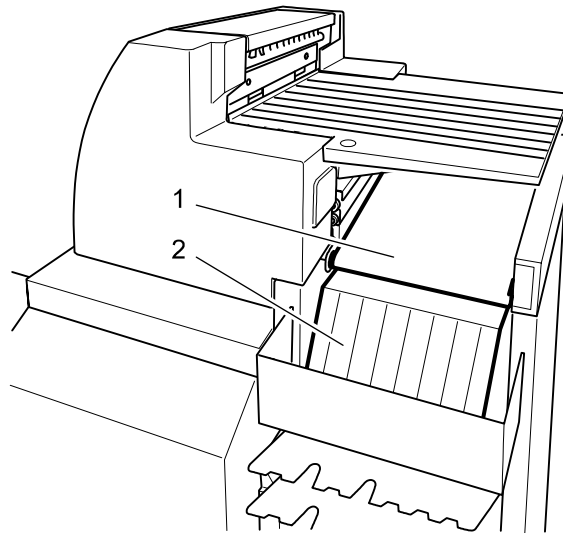

Monthly Maintenance

Checking the Solution Temperatures

1. Touch:
 - **Settings**
 - **Machine settings**
 - **PP temperature**
2. Set the reference temperatures for the solutions and the dryer, if necessary:

DEV	40 °C ± 0.3
BX	38 °C ± 2
STB	37 °C ± 2
Dryer	65 °C
3. Calibrate the temperature sensors:
 - a. Touch **Readjust xxx**.
A window with a numeric keypad opens. The temperature of the selected solution is indicated in the first line of the input field.
 - b. Remove the chemical filter.
Using a calibrated thermometer, measure the current temperature of the processing solution through the free opening of the filter holder.
 - c. Enter the current temperature value via the numeric keypad.
The sensor will be calibrated after pressing **OK**.

NOTE: The **Reset reference** and **Reset calibration** buttons are used to enter the standard values of the database.

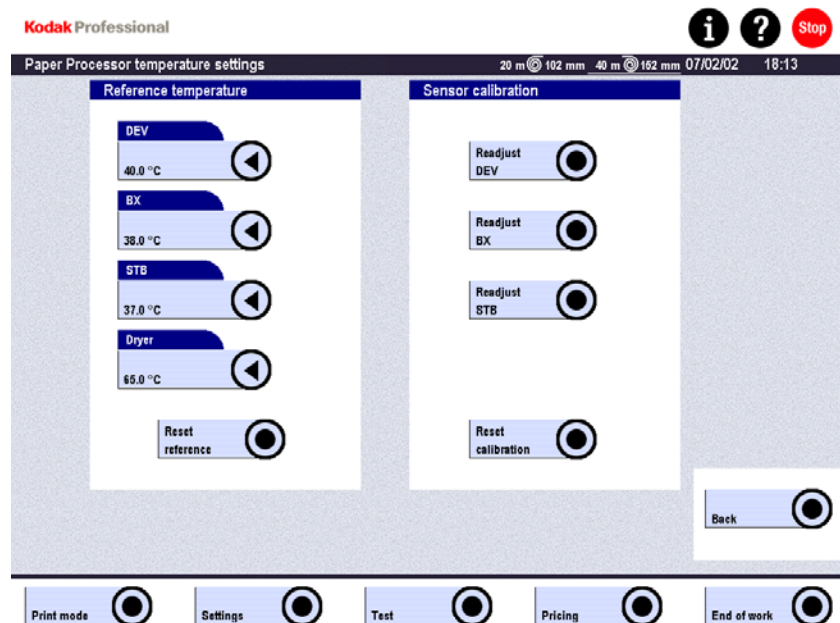

Cleaning / Replacing the Air Filters

CAUTION: Let washed filters and filter mats dry well before reinstalling them.

Do not wring, bend or press filters and filter mats.

Do not let filters and filter mats dry in the sun.

Below the Cutter Unit

1. Remove the cover (1).
2. Wash the filter mat in water. Replace the cutter unit air filter if it is too dirty.
3. Reinstall in the filter mat.

NOTE: Observe the correct position. The smooth side should point to the grid.

4. Mount the cover.

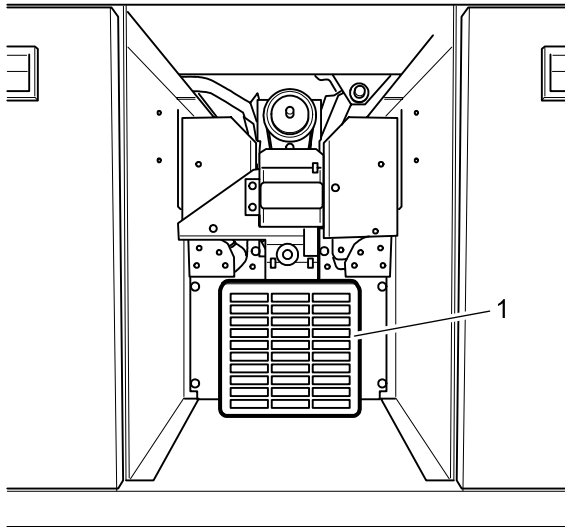

Door to Print Engine

NOTE: The filter is mounted on the housing of the exposure gap fan on the inside of the print engine door. The filter holder is fastened to the housing by 2 black locking screws (1).

1. Loosen the locking screws (1) and remove the filter holder (2).
2. If the filter mat is not excessively dirty, wash it in warm water.

CAUTION: Do not bend or wring the filter mat. Broken fibers may be blown into the print engine.

3. Remove all water and insert the dry filter in the filter holder.
4. If the air filter is extremely dirty, replace it.
5. Fasten the filter holder again.

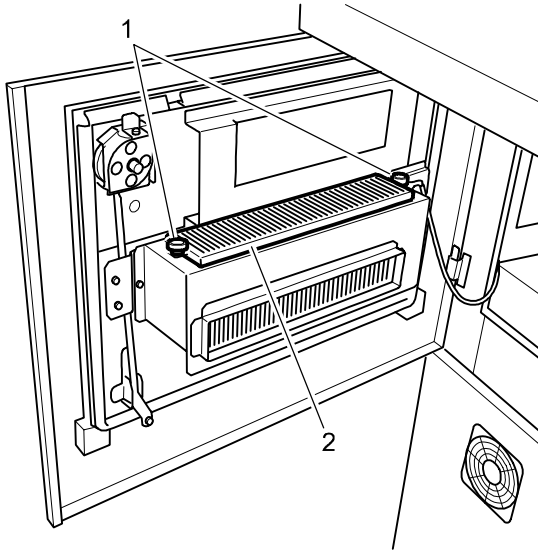

Right-hand Side Wall, Dryer and AC Power Supply of the Paper Processor

NOTE: The air filters 1 and 2 are mounted in holders of perforated metal. To remove the holder, lift it by the handle and pull it out to the front.

1. Blow out the air filters from the inside with compressed air, or wash them in warm water if they are very dirty.
2. Replace very dirty air filters together with the holder.
3. Put the air filter in the holder and insert the holder again.

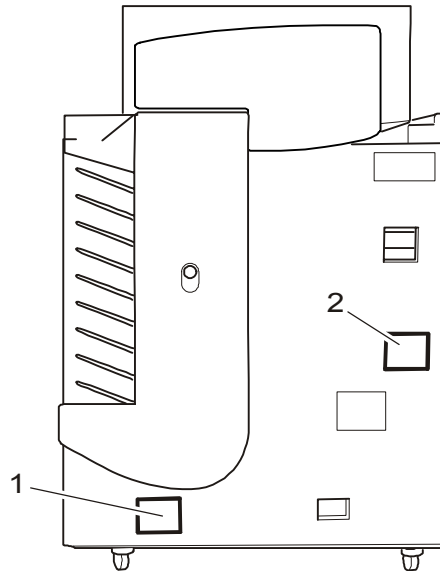

Changing Chemical Filters

WARNING: *Risk of injuries exists if the cover of the wet section unlocked accidentally or carelessly. See the Warning under Cleaning the Paper Processor on Page 8-13.*

Wear protective gloves and goggles when performing this procedure.

1. Open the paper processor cover and let it lock in the vertical position.
2. Remove the chemical filters and put them in a lab tray.
3. Pull the used filter cartridges off the shaft and install the new filter cartridges.
4. Rinse the filters to remove loose fibers.
5. Reinstall the chemical filters in the color-marked order.

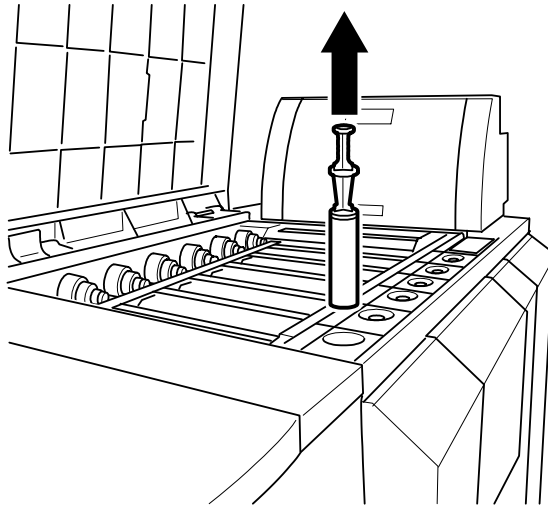

Cleaning the Processing Racks

Purpose: To ensure optimum processing quality.

WARNING: *Wear protective gloves, a rubber apron, and goggles when you clean the processing racks.*

CAUTION: *Chemical splashes may stain the covers. Use the splash guard (1) or remove splashes immediately with water.*

1. Remove the CD (Color Developer) feed unit, the tank crossovers and the squeegee unit.
2. Put the splash guard (2) on the CD rack to prevent the CD solution from being contaminated by BX.

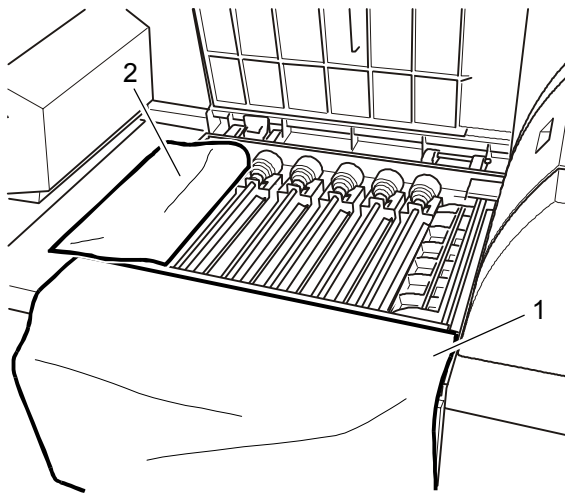

3. Open the rack locks. Lift the racks SB1 to SB4 and let the excess chemical solution drip from the racks.

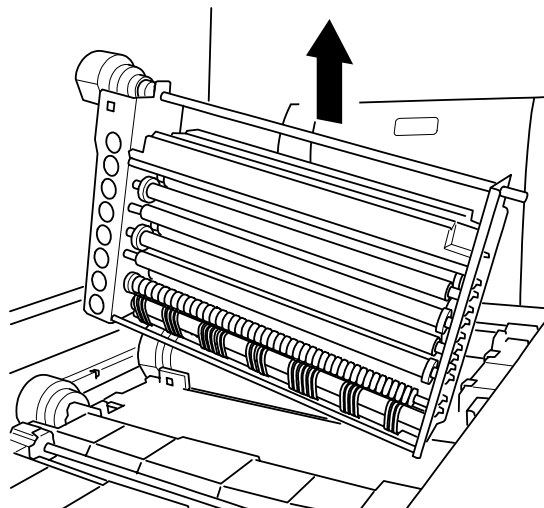

4. Lift the BX rack far enough so that the hinged holding plate can rest on the metal bracket to let the chemical solution drip from the rack.
5. Remove the dripped racks, put them in the tray supplied as accessory and take them to a lab basin.
6. Remove the splash guard from the CD rack.
Then repeat the above procedure with the CD rack.
7. In the lab basin, rinse the racks first in cold water, then in warm water (maximum 40 °C).
8. Clean the rollers and gears on the outside with warm water and a soft brush; remove any crystal deposits that may stick to the lateral drive gears.
9. Dismount the guide elements to clean the inside rollers. For this, press together the bearings clipped into the side parts at the catches and take them out.
On the CD and BX racks, dismount in addition the four styrodur displacers mounted in holders on both sides.
10. Clean the rollers with a soft brush. Clean the guide elements with a lint free cloth and warm water.
11. Let the racks drip dry.
Mount the guide elements; clip the bearings of the guide elements safely into the plates.
Mount the displacers and fasten them safely in the holders.
12. Check the smooth movement of the racks by turning the drive gear.
13. Check the drains at the back of the tanks. Remove any crystallization that may be there.
14. Insert the cleaned racks slowly into the tanks in the correct order.
15. Clean the CD feed unit, the crossovers and the squeegee unit and put them back.

16. Before mounting the squeegee unit, put back the protective plate underneath.
17. Close the processor cover.

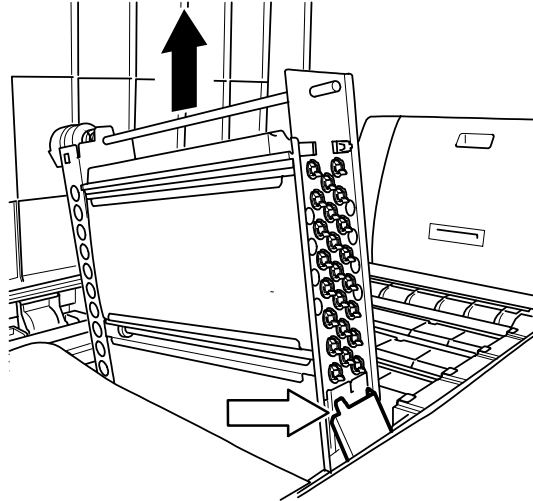

Arrow, white Hinged holding plate,
on the CD and BX racks

Cleaning the Dryer Rack

Necessary tools are:

- Screwdriver or coin
- Lint-free cloth and warm water

1. Remove the dryer cover. Use a coin to turn the lock by 90°.
2. Loosen the locking screw (knurled screw 1) of the dryer rack. Pull out the rack on the telescopic rails.
3. Remove only the feed roller set after unscrewing the knurled screw (2) and put it in water over the weekend.

CAUTION: If the rollers are not mounted prior to the automatic start after the weekend, be sure to deactivate the automatic MBL (Master Balance) in order to prevent a paper jam.

On Monday before starting to work, wipe off all deposits on the feed rollers and the feed plate with a damp cloth.

4. Clean the guide roller behind the feed rollers with a damp cloth.
5. Check all foam plastic rollers (3) for damages and replace them if necessary.

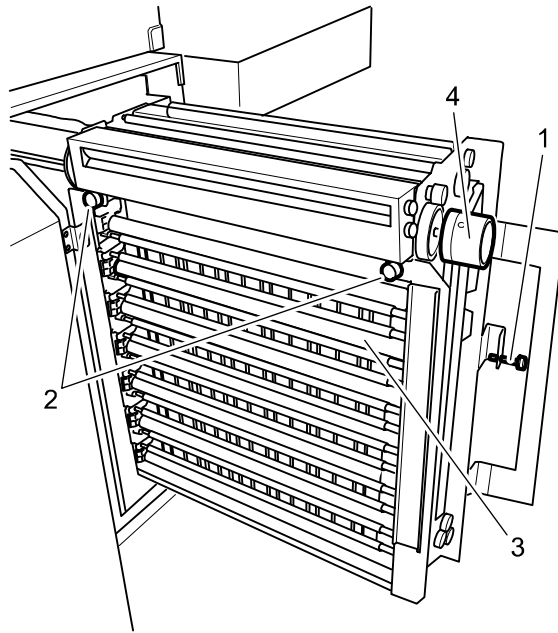

6. Clean the hinged guide grids (see *Figure*) with a damp cloth to remove all chemical deposits (crystalline sheet bridge deposits).
7. Carefully mount / clip in the guide grids.
8. Finally mount the bracket with the feed roller set on the rack.
9. Check the smooth movement of the rack by turning the handle (4) (see previous *Figure*).
10. Push the dryer rack in the dryer cabinet and fasten it with the knurled screw.
11. Put back the covers.
Turn the locks through 90°; push them in up to the locking point.

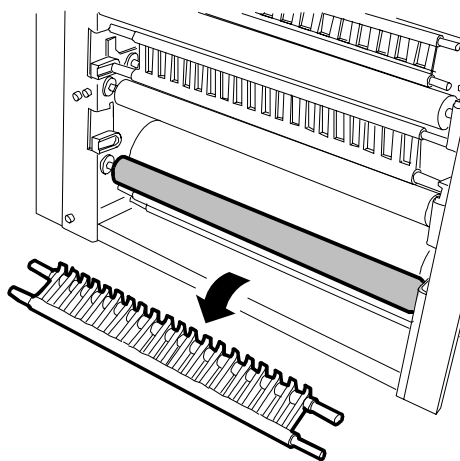

Cleaning the Paper

Cleaning / Replacing the Air Filters

NOTE: The filter with holder is mounted on the fan that is next to the densitometer.
Access after opening the flap on the paper outlet.

1. Remove the front cover of the paper outlet (1): Loosen the screw (2).

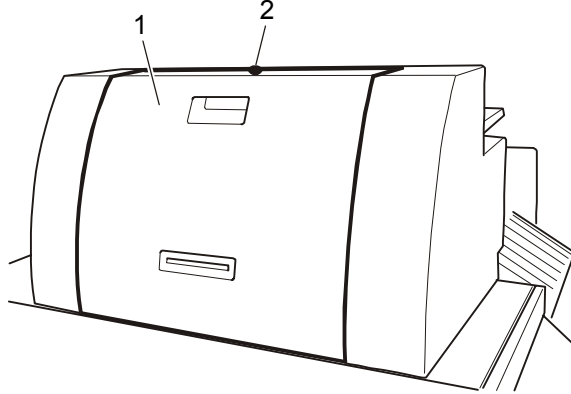

2. Remove the holder (1) from the fan housing.
3. Wash the filter mat if it is not very dirty.
4. Replace very dirty air filters.
5. Put the filter in the holder and insert the holder again.

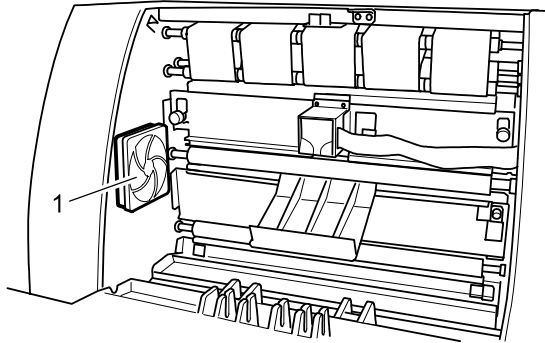

Cleaning the Guide with the Feed Chute

1. Unscrew (1) the guide plate (2) and lift it with the feed chute out of the supporting brackets.
2. Wipe the rear guide plate and the removed plate with a damp lint free cloth.
3. Put the guide plate in the supporting brackets, push it down and fasten it (1).

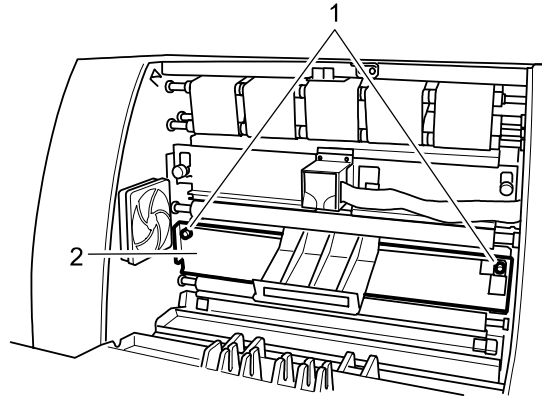

Cleaning the Rubber Transport Belts

CAUTION: Only clean the rubber transport belts and the rollers in the paper outlet unit while the transport is switched off.

Necessary tools are:

- Lint-free cloth and warm water
- Vacuum cleaner
- Soft brush

Purpose:

To ensure reliable paper transport.

Rubber transport belts for poster sizes (1), above the densitometer:

Clean the visible part of the transport belts with a damp cloth.

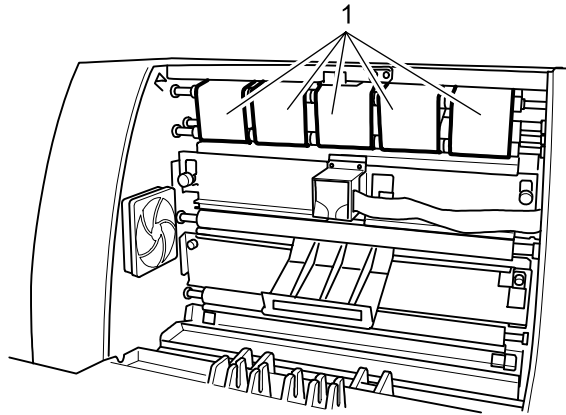

Paper transport on the output side for standard sizes:

1. Remove the deposit tray for the larger size prints.
2. Clean the visible part of the transport belts with a damp cloth (1).

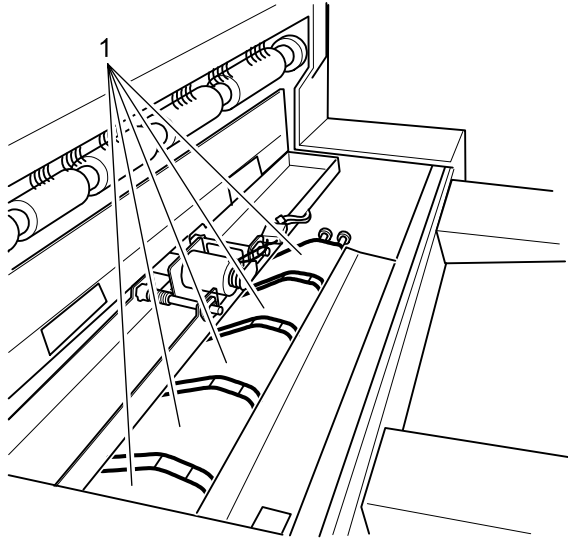

3. Unlock the quick-action locks on the guide plate (1) in front of the output rubber rollers. Remove the guide plate.
4. Clean the dust in the output area with a vacuum cleaner.
5. Clean the four light barriers in front of the output rubber rollers with a brush.
6. Put back the guide plate and fasten it safely with the quick-action locks.

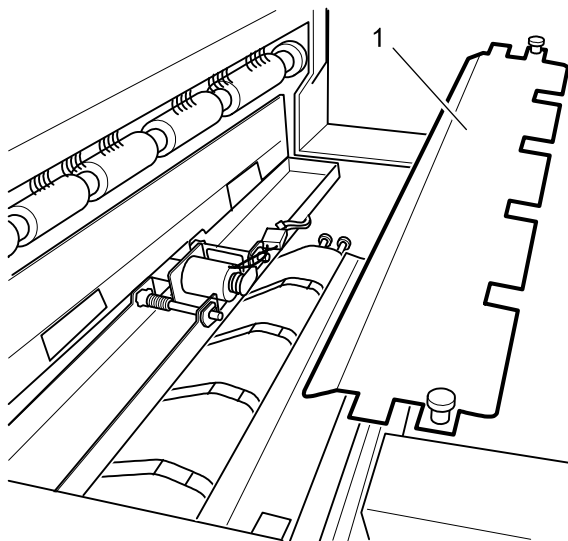

Transport belt of the print chute

Clean the transport belt (1) with a damp cloth.

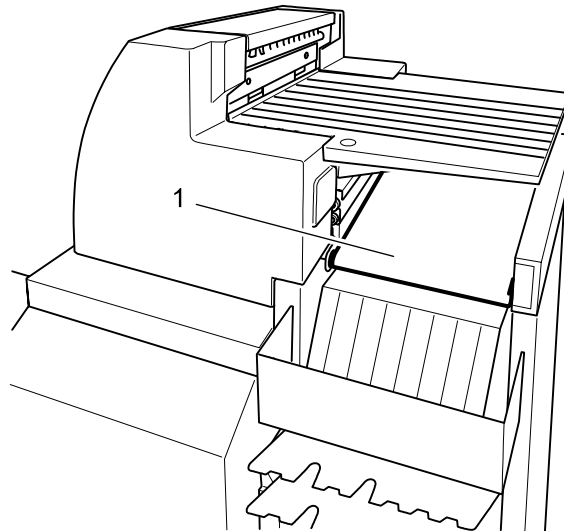

Maintenance When Required

Changing the Ink Ribbon on the Back Printer

When the printing on the back of the prints gets too faded, the ink ribbon must be replaced.

1. Unscrew the locking screw (1, red) of the lane distributor.
2. Pull out the unit on the telescopic rails.
3. Unscrew the knurled screws (2) and remove the top cover of the back printer.
4. Remove the ink ribbon cartridge by slightly pushing in both sides (3).
5. Prepare the new ink ribbon cartridge:
If present remove the foil strip on the ink ribbon. The ink ribbon must be tight in the cartridge; if necessary tighten by the knob (4) (note the direction indicated by the arrow).
6. Insert the ink ribbon cartridge.
7. Slightly turn the knob (4) on the cartridge until the cartridge locks in audibly.
8. Push in the lane distributor unit and tighten the locking screw.

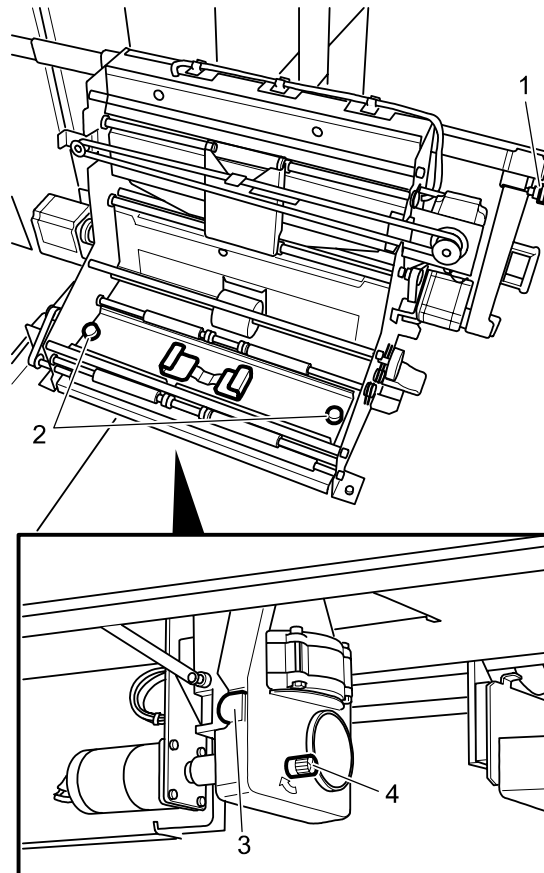

Emptying the Effluent Tanks

WARNING: *Wear protective gloves, a rubber apron, and goggles when you empty the effluent tanks.*

As soon as one of the effluent tanks is full, a message appears on the screen advising that this tank must be emptied.

NOTE: It is possible to touch **Clear** to suppress the message and to continue the work for a while. When the message appears for the third time, it can no longer be cleared.

Empty the full tank:

1. Open the front door at the bottom left of the paper processor. Position (1) marks the drain valves to be opened to empty the effluent tanks.
2. Put a bucket under the respective drain valve. Open the valve and empty the tank. Close the valve.
Perform the same procedure with the adjacent second valve.

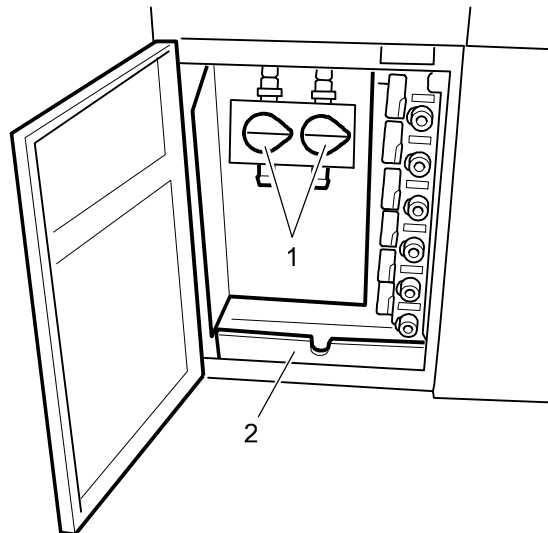

CAUTION: **Do not open both valves at the same time. The volume of both tanks is 20 L.**

IMPORTANT:

- *Do not open the drain valves in the vertical position on the right side. They are used to empty the processing tanks CD, BX and SB1 to SB4, for example, when a completely new tank preparation has to be filled into single or all tanks.*
- *Check the pan (2): If it is full although the customer emptied the tanks always in time, a technician must be called. The hose systems could be defective.*

Consumables

Chemicals

Chemicals	CAT No.
KODAK EKTACOLOR Processing Cartridge 75	528 3345
KODAK EKTACOLOR RA Developer Starter	102 6681

Air Filters

Air Filter	CAT No.
Annual Air Filter Kit	849 3678

Other Consumables

Consumable	CAT No.
Chemical Filters	113 3453
Backprinter Cartridges	826 0739
KODAK PROFESSIONAL Pro Strips for Process RA-4	129 8587

KODAK PROFESSIONAL Digital III Paper

Rolls in. x ft	Rolls cm x m	Surface	Catalog No.
3 $\frac{1}{2}$ x 577	8.9 x 176	E	871 5989
		F	896 8570
4 x 577	10.2 x 176	E	892 4664
		F	180 0036
		N	855 1392
5 x 577	12.7 x 176	E	855 6276
		N	115 3006
6 x 577	15.2 x 176	E	178 8710
		F	178 3380
8 x 262	20.3 x 88	E	828 5041
		F	802 9134
		N	860 6014
8 x 577	20.3 x 176	E	886 1064
		F	889 7290
		N	804 3499
8 $\frac{1}{4}$ x 262	21 x 80	F	894 0223
		N	895 8019
8 $\frac{1}{2}$ x 577	21.6 x 176	E	835 6297
		F	883 5910
10 x 288	25.4 x 88	E	898 7034
		F	107 0523
		N	191 6816
10 x 577	25.4 x 176	E	831 0930
		F	838 3432
		N	866 7743
11 x 288	27.9 x 88	E	846 6740
		F	864 9865
		N	109 2105
11 x 577	27.9 x 176	E	870 5204
		F	823 1730
		N	832 1770
12 x 288	30.5 x 88	E	171 5127
		F	192 2434
		N	800 5670

EASTMAN KODAK COMPANY
Rochester, New York 14653
U.S.A.

Kodak and Kodak Professional are
trademarks of
Eastman Kodak Company.



EASTMAN KODAK COMPANY
Kodak Professional Division
Rochester, New York 14650
www.kodak.com/go/professional
© Eastman Kodak Company, 2002.
TM: Kodak, Kodak Professional
P/N 6B7444

